

THE UNITED REPUBLIC OF TANZANIA
MINISTRY OF EDUCATION, SCIENCE AND TECHNOLOGY
NATIONAL EXAMINATIONS COUNCIL OF TANZANIA

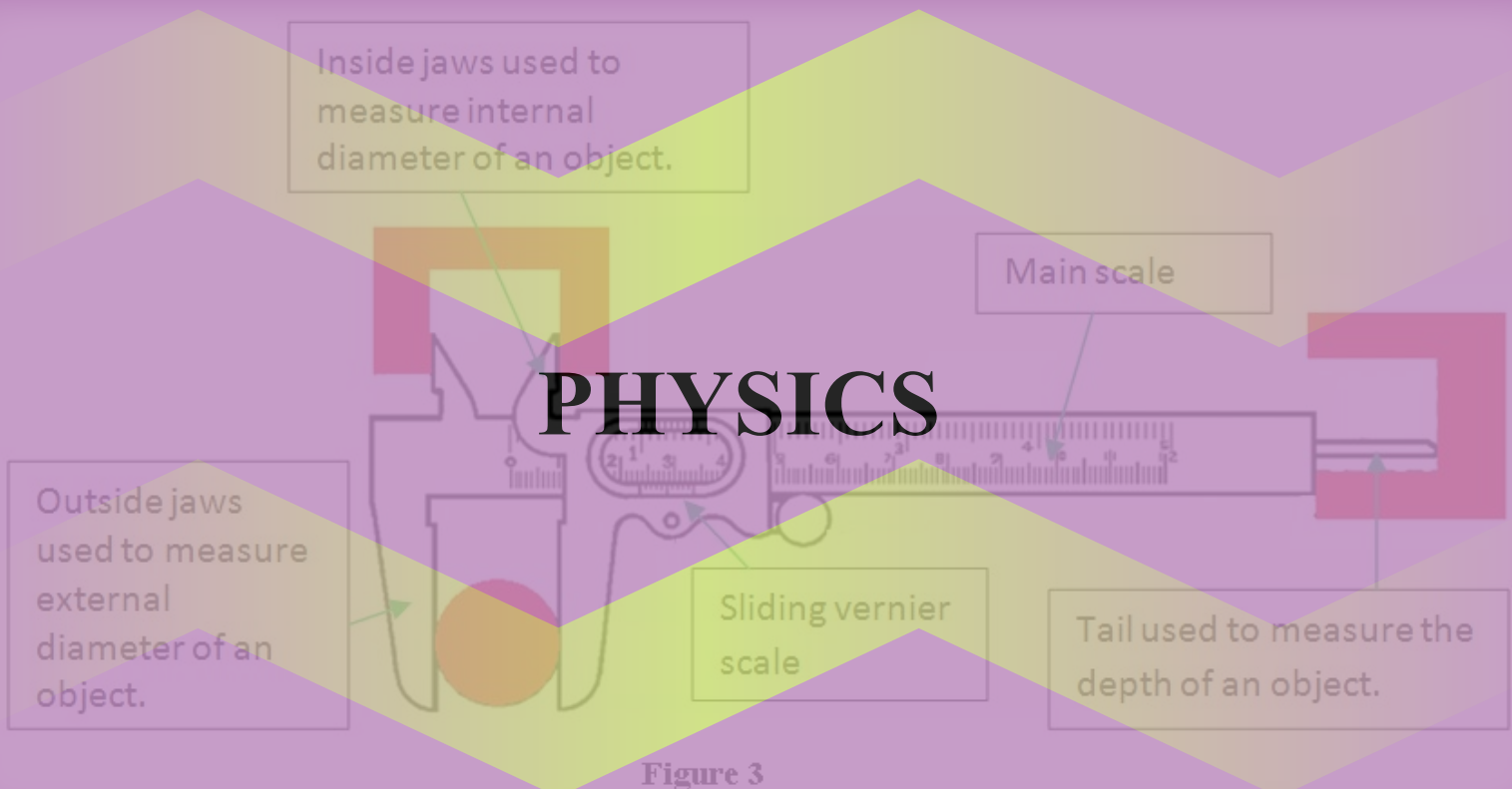

GUIDELINES FOR PREPARING THE LABORATORY FOR PRACTICAL EXAMINATIONS AT SECONDARY AND DIPLOMA IN SECONDARY EDUCATION LEVELS



Prepared by:
The National Examinations Council of Tanzania,
P.O. Box 2624,
Dar es Salaam, Tanzania.

October 2021



THE UNITED REPUBLIC OF TANZANIA
MINISTRY OF EDUCATION, SCIENCE AND TECHNOLOGY
NATIONAL EXAMINATIONS COUNCIL OF TANZANIA



GUIDELINES FOR PREPARING THE LABORATORY FOR PRACTICAL EXAMINATIONS IN SECONDARY EDUCATION AND DIPLOMA IN SECONDARY EDUCATION LEVELS

PHYSICS

Prepared by:
The National Examinations Council of Tanzania,
P.O. Box 2624,
Dar es Salaam, Tanzania.

October 2021

Published by:
The National Examinations Council of Tanzania,
P.O. Box 2624,
Dar es Salaam, Tanzania.

© The National Examinations Council of Tanzania, 2021
First Edition, 2021

All rights reserved.

Table of Contents

FOREWORD	iv
1.0 INTRODUCTION	1
2.0 LABORATORY ORGANISATION, MANAGEMENT AND SAFETY MEASURES	1
2.1. Laboratory Organisation	1
2.2. Laboratory Management	2
2.3. Risk assessment in the Physics Laboratory.....	4
2.4. Laboratory Safety Measures	6
2.5. Key Responsibilities of Laboratory Technicians/Teachers in charge.....	8
3.0 Checking Laboratory Equipment, Apparatuses and Tools	9
4.0 AREAS OF ASSESSMENT	16
4.1. Measurement	17
4.2. Archimedes Principle and Law of Floatation	19
4.3. Structure and Properties of Matter	22
4.4. Forces in Equilibrium.....	26
4.5. Motion in a Straight line	28
4.6. Friction	29
4.7. Simple Harmonic Motion.....	31
4.8. Rotation of Rigid bodies	33
4.9. Fluid Dynamics	35
4.10. Light	36
4.11. Heat/Masurement of Thermal Energy	40
4.12. Vibrations and Waves	45
4.13. Current Electricity.....	46
5.0 CONCLUSION.....	50

FOREWORD

The National Examinations Council of Tanzania (NECTA) administers practical examinations in the Certificate of Secondary Education Examinations (CSEE), Advanced Certificate of Secondary Education Examinations (ACSEE) and Diploma in Secondary Education Examinations (DSEE). The examinations aim to assess knowledge, skills and competencies that the candidates have acquired by testing them on facts practically under controlled experimentation and observations. Through practical examinations, skills and competences of students in the subject are effectively evaluated.

This guide is designed to help Physics teachers, tutors and laboratory technicians who handle practical preparations in laboratories to perform their tasks effectively and efficiently. The guide presents important instructions on how to organise and prepare the laboratory for examinations. It offers step-by-step guide notes to help teachers in preparing and administering practical examinations

The guide can also serve as a tool for promoting the teaching and learning process as those organising and preparing laboratories for examinations also acquire skills and learn procedures for conducting different Physics practicals. In this regard, a thorough analysis of the Physics syllabuses preceded the determination of areas for practical assessment. As such, the guide describes the areas of assessment, objectives for conducting different practicals, materials, apparatuses, equipment and chemicals for use in the practicals, procedures for conducting such practicals and sample questions for practicals. These aspects have been deliberately included to ensure smooth and fair conducting of examinations in order to have uniformity in all Physics examination centres.

The Examinations Council urges teachers, tutors and laboratory technicians to use this guide to improve their practice in preparing practical examinations to enhance smooth conducting of Physics examinations.

The Council expresses its sincere thanks to teachers, examination officers and all other members of staff who participated in the preparation of this handbook.



Dr. Charles E. Msonde
EXECUTIVE SECRETARY

1.0 INTRODUCTION

This guideline is designed to foster the understanding of fundamental principles and laws of Physics. It also seeks to help teachers/ laboratory technicians and learners to apply the acquired skills on gathering and analysing the data to measure the validity of the tested concepts so as to reach a meaningful conclusion.

This Physics guidebook is a source of knowledge, problem-solving skills, intuition and practical experience with apparatuses and data collection procedures. It details techniques to help teachers/ laboratory technicians organise and prepare practicals for topics such as *Measurement, Archimedes Principle and law of Flotation, Structure and Properties of Matter, Forces in Equilibrium, Motion in a Straight Line, Friction, Simple Harmonic Motion, Rotation of Rigid Bodies, Fluid Dynamics, Light, Heat/Measurement of Thermal Energy, Vibrations and Waves* and *Current Electricity* effectively.

An experiment usually involves setting out an objective, establishing a valid procedure for achieving the objective performing the experiment and getting the results, interpreting the outcome and, finally, presenting the resultant findings. This guidebook addresses different aspects including how to organise and manage a Physics laboratory, safety rules, areas of assessment, specific objectives, key issues for consideration, sample questions, apparatuses and necessary procedures. All these aspects facilitate understanding, hence creating confidence when performing practicals.

This guidebook is crucial for both teachers/laboratory technicians and students in acquiring the required proficiency in physics principles, problem-solving skills and concepts of experimental practice and analysis. It also presents rules for them to observe while in a physics laboratory. Consequently, it will facilitate the identification and assembling of apparatuses as per instructions, the preparation of tables of results, recording of actual observations, plotting of graphs, analysis of data, and drawing of conclusions based on the observations made.

Generally, this guidebook will serve as a supportive basis for Physics teachers/ laboratory technicians to broaden and enrich their knowledge and skills in preparing practical examinations.

2.0 LABORATORY ORGANISATION, MANAGEMENT AND SAFETY MEASURES

A laboratory is a place for carrying out scientific experiments/demonstrations. Laboratory organisation and management skills are essential for effective teaching of the Physics subject. Ensuring safety in the laboratory requires employment of different skills during the Physics teaching and learning process.

2.1. Laboratory Organisation

Laboratory organisation entails the way a laboratory and its operation are handled. One of the most important things to consider in the laboratory is organisation. This is primarily because efficiency in the laboratory help to save time and running costs. The following are some of the important tips on organising a laboratory:

- (i) keeping apparatuses, equipment and other materials within reach;
- (ii) keeping laboratory notebooks away from your central workplace;

- (iii) creating designated spots for general supplies;
- (iv) organising supplies based on how often you use them;
- (v) labelling all the items accurately and accordingly; and
- (vi) performing regular audits of all the apparatuses.

How to Implement Laboratory Organisation

Organising a laboratory requires employment of a 5S method. This method provides a basis for making sure that laboratory safety and efficiency of the pre-preparation procedures are engendered. The method has five (5) distinct steps: Sorting, Setting, Shining, Standardising and Sustaining. As these steps feed into each other, the sequence is important for successful use of the method.

Step 1, Sorting: This step involves identifying equipment, apparatuses and materials in accordance with the areas of assessment/topics. The goal of this step is to eliminate clutter and clear up the laboratory space by removing apparatuses and materials that do not belong in it.

Step 2, Set: Arrange the apparatuses and materials to be easily selected for use. This prevents loss and waste of time by arranging the apparatuses and materials in such a way that they are close by.

Step 3, Shine: Clean the laboratory and all the equipment, apparatuses and materials and keep them clean and tidy, ready for the next user.

Step 4, Standardize: Maintain high standards of laboratory organisation at all times. This involves incorporating laboratory practices into normal work procedures by writing down what to be done, where, and by whom.

Step 5, Sustain: Now you have created a 5S workspace. It is very important to keep that way. Create a 5S audit to ensure that, the apparatuses and materials get sorted out, set in place and cleaned. Get everyone involved. Motivation and commitment are essential for effective implementation of 5S. Create a reward system to encourage people to maintain high standards of 5S. Use 5S audit sheets as a scorecard for inter-lab competition. Make 5S visible by displaying posters or newsletters and signage to create a constant reminder about 5S.

2.2. Laboratory Management

Laboratory management guides laboratory personnel to deliver their duties within limited time and resources.

NB: One important aspect of laboratory management is to ensure that the laboratory condition and personnel are up to contemporary standards.

Laboratory management is mainly concerned with the following:

- (i) provisions of materials for laboratory work;
- (ii) ensuring heating, water, electrical and gas systems are working properly;
- (iii) maintenance and repair of equipment; and
- (iv) proper organisation of the laboratory and auxiliary services (i.e. record-keeping storing materials, issuing materials and proper operations of the laboratory);

- (v) apparatuses such as measuring cylinders, beakers, burettes, test tubes and others should be stored clean;
- (vi) calibration of instruments should be done before experiments;
- (vii) integrate and coordinate organisational resources so that quality laboratory services can be provided as effectively and efficiently as possible. Organisational resources include personnel, equipment, running costs, time and space;
- (viii) overseeing the daily operation of the laboratory; and
- (ix) giving technical advice and keeping records of laboratory activities or incidences in the laboratory ledger book.

How to Implement Laboratory Management

To manage the laboratory, the teacher/laboratory technician in charge needs to acquire laboratory management skills which include;

Ordering/ Procurement Skills

- (i) Obtain quotations for items from more than one laboratory equipment suppliers.
- (ii) Order necessary and relevant laboratory apparatuses and materials.
- (iii) Ensure priority placement on ordered items.
- (iv) Ensure that the necessary apparatuses and materials ordered for are supplied.
- (v) Arrange with knowledgeable laboratory equipment suppliers.
- (vi) Check for and reject fake laboratory apparatuses and materials.
- (vii) Compare the cost of the materials to their qualities and advise the school management.

Stocking/Storage Skills

- (i) Provide and use a ledger book(s).
- (ii) Prevent glassware breakage by not storing them in nest pattern.
- (iii) Record damages and breakages properly.
- (iv) Ensure proper disposal of broken glassware.

Maintenance Skills

- (i) Ensure that drainages are functional.
- (ii) Inspect apparatuses and electrical appliances before allowing students to use them.
- (iii) Ensure that used laboratory apparatuses are washed and packed.
- (iv) Prevent and amend leakages of water and gas.
- (v) Repair equipment with minor problems.

Calibration Skills

A person in charge of the laboratory need to have a good mastery of skills as analysed hereunder:

- (i) Must be able to critically analyse problems and come up with innovative solutions. This may include taking raw test data and analysing it accurately, reaching conclusions;
- (ii) Must be a master of testing and calibrating tools such as electrical apparatuses, oscilloscopes, probes and its accessories etc.
- (iii) Must be able to set up, test equipment/instruments and troubleshoot them or components.
- (iv) The ability to prepare service/calibration reports and accurately document parts that require replacement and repair. The report compiled has to be shared with the school

management or directly dealt with by contacting the suppliers for replacement of the equipment/instruments.

- (v) Must be able to communicate effectively with the head of department/school management/suppliers to solve the instruments' problems.

2.3. Risk assessment in the Physics Laboratory

Before conducting any experiment in the laboratory, the teacher in charge or laboratory technician should inform students about the hazards and potential risks to them or the equipment/instruments. Meanwhile, the risk refers to the likelihood or probability the hazard to cause actual harm and the severity of the results. Risk assessment, therefore, involves careful examination of the premises, processes and activities to identify what can cause harm to people in order to know whether sufficient precautions have already been taken or further measures are to be taken. Risk assessment intends to safeguard teachers in charge/laboratory technicians, students and the apparatuses/equipment in any physics experiment. To assess the risk of any Physics experiment, teachers in charge or laboratory technicians, should:

(a) Identify the hazards in an experiment

The first step is to identify the hazards in the experiment. These might be electrical problems, leakage of radioactive materials, high temperature (burns and scalds), and high pressure with a chance of an explosion. There are then simple physical hazards around laboratory. These are usually things that you can trip over. As such, store bags and briefcases under the bench and avoid having electrical leads trailing from one bench to another across an open space. If possible, do not store heavy or expensive equipment in high cupboards where it could fall out, hit somebody and break.

(b) Risk Assessment

Having identified the possible risks in an experiment one should then consider the worst possible situation and look at it from two points of view:

- the possible effect; and
- the chances of it to happen.

The following outline the effects and opportunities of occurrence of hazards they are graded, with 1 with 4 being the greatest risk and greatest chance of occurrence.

Possible effect

4. Death or permanent disability.
3. Long-term illness or serious injury.
2. Medical attention and several days off work/school.
1. First aid required.

Chances of it to happen

4. Very likely
3. Likely
2. Unlikely
1. Very unlikely

Note: Any experiment which could cause serious injury to staff or students should never be carried out in the school laboratory.

(c) Control

Having considered the risk and possible consequences, one should try to control the experiment to ensure that you can answer the following questions:

- Can you eliminate the risk?
- If the risks are significant, is there another way of carrying out the experiment or can you substitute an alternative experiment?
- Can you reduce the risk?

Controlling exposure to occupational hazards is a fundamental method for protecting teacher in charge/laboratory technician or students. Traditionally, a hierarchy of hazard controls has served as a means for determining how to implement feasible and effective control solutions. One representation of this hierarchy is as illustrated in Figure 1. The idea behind this hierarchy is that control methods at the top of the graph are potentially more effective and protective than those at the bottom.

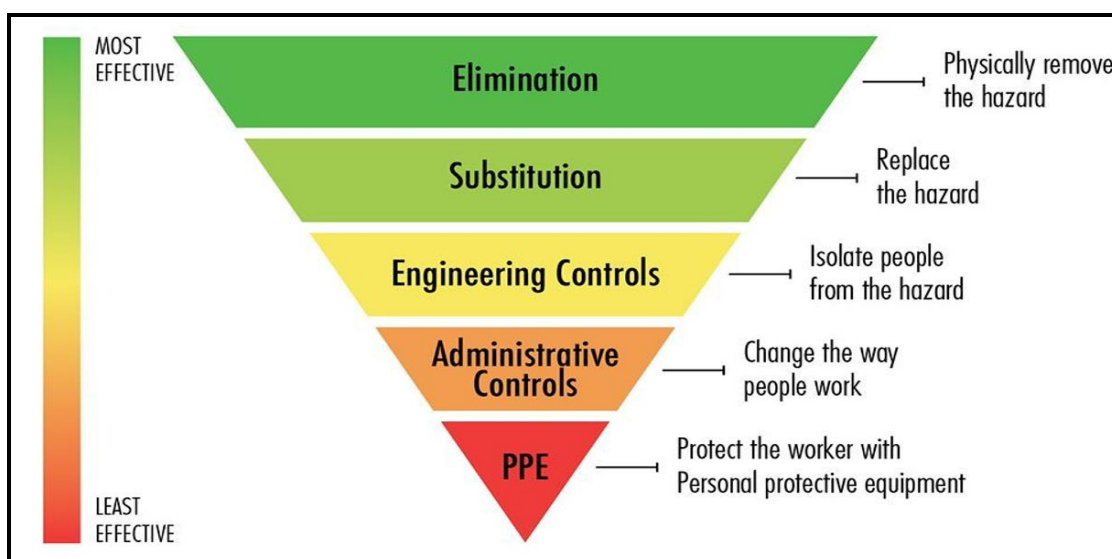

Figure 1

The hierarchy of hazard control has been customised in Physics laboratory as presented in Table 1:

Table 1: Hierarchy of Hazardous Controls in Physics Laboratory

S/n.	Control	Example
1.	Eliminate	Removing the hazard, e.g. Taking a hazardous piece of equipment/instrument out of service.
2.	Substitute	Replacing a hazardous substance or process with a less hazardous one
3.	Engineer controls	Redesigning an experiment, piece of equipment or process to make it less hazardous

S/n.	Control	Example
4.	Administrative	Adopting safe work practices and provide appropriate training, instruction or information
5.	Person Protective Equipment (PPE)	Use of lab-coat, gloves, safety glasses, safety footwear, dust masks, face shields, goggles, etc

2.4. Laboratory Safety Measures

To treat or eliminate the sources of danger while working in a Physics laboratory, students, teachers in charge and laboratory technicians should adhere to the safety measures. This can be done as follows:

- (i) the laboratory floor should not be polished to avoid slippery;
- (ii) open shoes and sandals should not be worn in the laboratory;
- (iii) wear protective gears such as aprons, overcoats, gloves and safety goggles where necessary;
- (iv) do not run in the laboratory and never shout unnecessarily in case of any accident and let other laboratory users know the nature of accident as soon as possible;
- (v) do not touch either the broken glass or split mercury with your bare skin;
- (vi) the laboratory should have large windows without iron bars and its doors should be easy to open outwards;
- (vii) maximum ventilation in the laboratory should be ensured;
- (viii) safe storage for apparatuses should be highly considered;
- (ix) know the location of the main switch and extinguishers for controlling electricity and fire in case of emergencies respectively;
- (x) make students aware of the appropriate use of electricity and dangers of misuse;
- (xi) when using batteries, always inspect them first for cracks and leaking. Discard in an appropriate environment for any of these conditions to occur;
- (xii) remove all conductive or metallic jewellery before you start working with electricity;
- (xiii) prevent trip and fall hazards by placing wires away from places where people walk;
- (xiv) for routine maintenance such as changing of bulbs, ensure the device is unplugged before initiating the work;
- (xv) never open a battery. Its contents are corrosive and can be toxic or poisonous;
- (xvi) when storing batteries, never allow the terminals to touch or short circuit;
- (xvii) avoid a watery environment and wet hands when dealing with cords, plugs or electrical equipment. Never run a cord near or over a sink;
- (xviii) utility pipes such as water and gas are grounded. Do not touch an electrical circuit and a utility pipe at the same time;
- (xix) never plug damaged electrical equipment into a wall receptacle, including frayed wires, missing ground pin and bent plugs; and
- (xx) never overload circuits as they will overheat and cause power outage or fire.

How to implement Laboratory Safety Measures

To treat or eliminate the sources of danger, the teacher in charge/laboratory technician needs to acquire safety skills, which include:

(a) Safety consciousness skills

Safety consciousness refers to awareness of the hazards and alertness to danger, which has a strong bearing on the actions of individuals because of their desire to stay alive and uninjured. Thus, the teacher in charge/laboratory technician needs to develop safety consciousness and make safety a value by observing the following eight simple steps:

- know the job and thoroughly familiarise oneself with the work plan;
- make, revise and utilise job safety analysis for tasks to be done;
- perform your work in a way that will not create or leave hazards, which may cause accidents and affect other employees or students;
- obtain training on first aid and thoroughly be familiar with the procedures of giving artificial respiration;
- take an active part in safety meetings;
- report all hazards, unsafe practices, and accidents. Correct all the observable hazards and correct safely;
- accept responsibility for using safety protective equipment in the laboratory; and
- teach your students, co-workers and others how to prevent accidents.

(b) Skills in the arrangement, handling and care of laboratory equipment and facilities

The Physics laboratory should have a well-organised equipment management programme. The programme should address equipment selection, preventive maintenance, and procedures for troubleshooting and repair. Good documents and records maintained include a complete and accurate inventory of all the laboratory equipment, documents provided by the manufacturers in the operation, maintenance, troubleshooting, and records of all the preventive maintenance and repair activities.

(c) Skills in experimental procedures

The practical aspect covers all the practical activities associated with Physics topics. These activities are sound and performed properly in accordance with the instructions regulating them. Failure to perform tasks due to lack of knowledge, negligence or haste may cause accidents. Thus, having awareness of safety measures of students and teachers, and abiding by the instructions during laboratory practices serves as a moral charter to be observed when performing laboratory experiments.

(d) Skills in the prevention of accidents in the laboratory

To prevent accidents in Physics laboratories, carrying out risk management is essential because the preventive aspect of laboratory work prevents or reduces risks for individuals and facilities, hence minimising losses and preventing the recurrence of accidents. Thus, the school laboratory staff including teachers, students, and technicians should be aware of the practices, tools, materials, and devices that could endanger their lives. They should also be aware of the expected injuries resulting from the misuse of such materials and devices.

(e) Skills in the provision of First aid and its administration

Basic knowledge of first aid is an essential life skill that everyone should have since nobody knows when they will find themselves amid a medical emergency whereby the

knowledge of these skills could save someone's life. The following list is an outline of five (5) most important first aid skills to be acquired by the teacher in charge/laboratory technician:

- **Cardiopulmonary Resuscitation (CPR)**

This fall-back protocol underlies all other first aid principles. CPR allows the rescuer to revive a person in a cardiac arrest by keeping oxygen moving to their brain until help arrives or the person recovers.

- **Management of choking (difficulty in breathing)**

If a patient suffers from a blockage in the upper airway, he is at risk of going into respiratory arrest. Knowing the correct skills will allow one to clear the airway and allow the victim to survive only suffering a scare. These skills enable a bystander to save the victim by clear a blocked airway.

- **Management of a suspected spinal/head injury**

Understanding the principles of spinal and head injuries is essential in saving lives and preventing further injury. By participating in a basic first aid course, one can learn the correct way to deal with and handle spinal and head injuries.

- **Correct Administration of an Adrenaline autoinjector (ANAPEN)**

ANAPEN is a new adrenaline autoinjector for the emergency treatment of acute allergic reactions with anaphylaxis. ANAPEN has an administration technique that is substantially different from that of EPIPEN and, therefore, specific training is required for each autoinjector.

- **Management of bleeding**

Severe bleeding can be life threatening with a short time. By learning the first aid principles regarding how to control bleeding one would have able to save a person suffering from bleeding.

2.5. Key Responsibilities of Laboratory Technicians/Teachers in charge

Laboratory technicians/teachers in charge who conduct the planned duties of laboratory management are responsible for the direction of the laboratory. They ought to make sure that the laboratory operation fits in with the laboratory vision and mission in the long-term. The following are some of their strategic roles:

- (i) setting laboratory objectives;
- (ii) designing long-term plans;
- (iii) overseeing laboratory operations and relevant regulations;
- (iv) assigning tasks, monitoring and evaluating staff progress, performance and customer satisfaction;
- (v) developing and administering the budget;
- (vi) reviewing regulatory requirements; and
- (vii) developing and administering the budget using a ledger book.

When a checklist is sent to schools/colleges, teachers in charge/laboratory technicians are required to make sure:

- (i) all the apparatuses, materials and equipment listed are available;
- (ii) the specifications given in the checklist should be adhered;
- (iii) the apparatuses, materials and equipment accommodate the number of candidates registered;
- (iv) the normal laboratory fittings are working properly; and
- (v) measuring instruments are calibrated.

To assess CSEE, ACSEE and DSEE Physics practical examination, practical instructions have to be provided 3 hours in advance whereby teachers in charge/laboratory technicians would be required to do the following:

- (i) handle with care the information given in the 3 hours practical advance instructions;
- (ii) read carefully and understand the list of apparatuses and materials provided in each category;
- (iii) arrange apparatuses and materials as prescribed in the 3 hours practical advance instructions;
- (iv) display the arranged list of apparatuses and materials on the bench according to the number of candidates registered in a particular examination;
- (v) make sure that each candidate has apparatuses and materials as per 3 hours practical advance instructions; and
- (vi) in case there is more than one examination session, teachers in charge/laboratory technicians ought to rearrange and replace (where necessary) the apparatuses and materials (where necessary) before the next session.

Note: *Notably, items (i) to (vi) holds to all experiments/areas of assessment for this guideline.*

3.0 Checking Laboratory Equipment, Apparatuses and Tools

The calibration process or checking of measuring instruments is important when working in the Physics laboratory.

Common apparatuses, equipment and materials as per checklist/Syllabus

Micrometer screw gauge, Vernier calliper, Ammeter, Voltmeter, Galvanometer, Battery holder, Jockey, Crocodile clips, Bulbs, Multi-metre, Resistance box, Rheostat, Standard resistors, Source of e.m.f., Connecting wires, Wires of unknown resistance (Manganin, Constantine and Nichrome), Meter bridge, Potentiometer, Wheatstone bridge, Beam balance and others.

Micrometer Screw Gauge

Micrometer screw gauges are of two types: Analogy and digital. A micrometer screw gauge is an instrument used to measure very small dimensions e.g. the diameter of a thin wire or small round object.

Do's and Don'ts of Micrometer Screw Gauge

Before taking any reading, teachers-in charge/laboratory technicians should observe the following (Do's):

- (i) using a ratchet, close the jaws until the anvil and spindle faces touch one another;

- (ii) make sure that the Zero mark of the thimble scale aligns with the datum line/central line of the main scale;
- (iii) when turning the ratchet, the thimble should be moved without stacking. Figure 2 is illustrative;

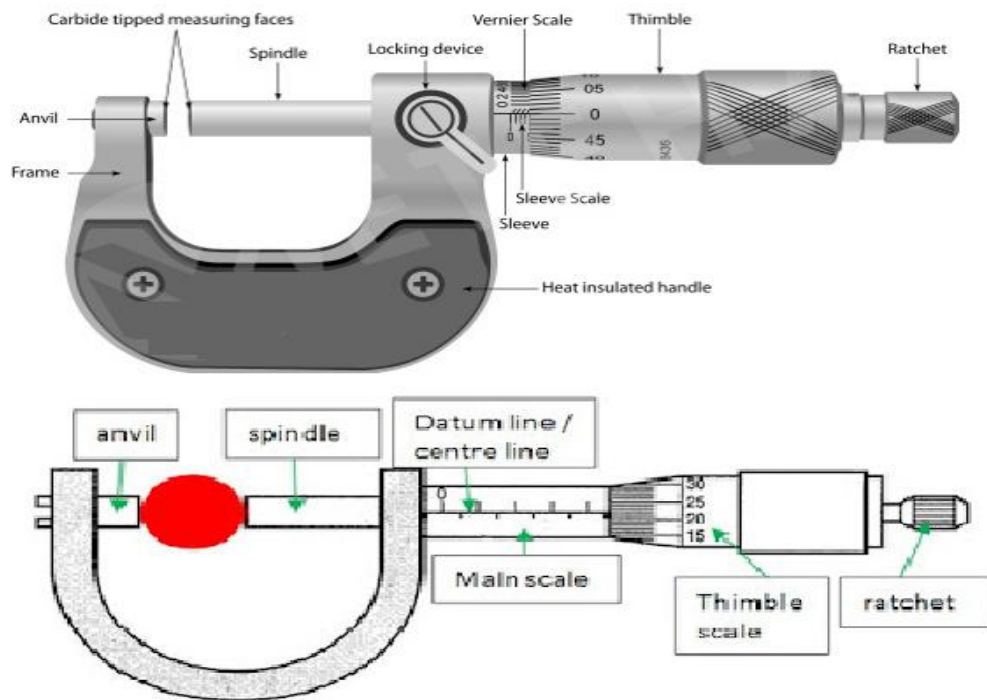

Figure 2

- (iv) the body used to hold the anvil and barrel firmly in their place is called a **frame**. It is a thick C-shaped frame with a mass which helps to minimise expansion or contraction due to temperature changes. Some manufacturers also deliver gauges with insulated frames to serve this purpose;
- (v) an **anvil** is the fixed part mounted at one end of a frame. It is parallel to the moving spindle which moves towards it. The anvil face, which comes directly in contact with the object being measured, is made extremely fine to achieve the highest degree of precision;
- (vi) a **spindle** is the cylindrical part, which is displaced by rotation of the thimble, hence reducing the clearance between itself and the anvil until the object being measured stabilises. In modern micrometer screw gauges, the anvil and spindle open face are tipped with carbide;
- (vii) a **sleeve/barrel** is a stationary part with a linear scale called the **main scale**. It also covers the screw mechanism of the screw gauge with adjustable sleeves, which makes it easy to eliminate the zero error;
- (viii) a **screw** is the most important part of the instrument because all the measurement is done through it. Very fine stainless-steel screws are used for this purpose with a definite pitch;
- (ix) a **thimble/circular scale** is the part through which a measuring screw is rotated. The screwing results in the displacement of the spindle and the thimble itself;
- (x) a **ratchet** is a small device used to provide a limited applied force. It is installed at the right end of screw gauge and serves as a safety device for instruments. Moreover, it adds more precision in measurement. The final adjustment is made by making three turns of the ratchet; and

- (xi) a **locking device** is a nut whose operation is facilitated by a lever, usually used to hold the spindle tight in its place so that the current reading of that time could be maintained up to a desired time.

Note: Some micrometer screw gauges are created in such a way that the zero error can be corrected using a screwed anvil. It can move back and forth depending on the possible adjustment to remove the **Zero error**. You can insert a screw-driver at the back side of the anvil and turn it to remove the **Zero error** while positioning the zero mark of the thimble scale in line with the datum line.

Don'ts of Micrometer Screw Gauge

Never close the jaws using the thimble. You might end up dis-positioning the scales and creating zero error in addition to deforming the object to be measured.

Vernier Calliper

Vernier Callipers are of two types: **Analogue** and **digital**. Vernier Calliper consists of the main scale and the sliding Vernier scale used to measure both the internal and external diameters as well as the depth of the objects. Figure 3 is illustrative:

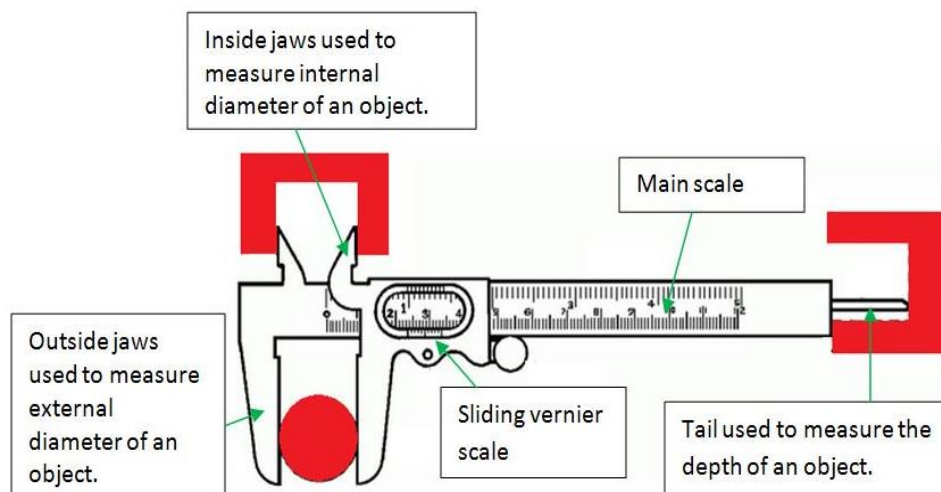

Figure 3

Do's and Don'ts of Vernier Calliper

Before taking any reading teachers-in charge/laboratory technicians should observe the followings (Do's):

- (i) when using analogue Vernier Callipers, we must **check for zero error**. This is done by checking **whether two zero marks coincide with each other** when we are not measuring anything (jaws are in contact with each other). Zero error is always observed on **the Vernier scale**;
- (ii) when using electronic/ digital Vernier Callipers, one of the most frequent issues to check is the fluctuation of the **zero reading** when the jaws are closed; and
- (iii) electronic/digital calliper has a zero button to reset the value. This should be the first thing to do before taking a reading. To ensure proper zeroing:

- close the jaws of the callipers and press zero;
- slide it and bring it back to the position a couple of times to check whether it is holding;
- the measuring jaws should be cleaned properly before closing them; and
- adjust the jib screws located under the movable jaw. If they are loose, a disturbance can occur in the jaw causing the readings to fluctuate.

Note: A quick check before zeroing is to close the jaws and hold them in front of a source of light. If light passes between the gaps, either the jaws need to be pressed more or the surfaces may have suffered mechanical damage. In this case, the digital Vernier Callipers may need to be replaced.

Don'ts of Vernier Callipers

Although taking measurements with a digital Vernier Calliper is much more simplified than using a regular/analogue Vernier Callipers, the followings should be discouraged:

- never apply too much force on the jaws as it can easily shift the reading; and
- the object to be measured should not be placed on the tips since this produces a higher moment causing the jaws to bend on excessive force.

Ammeter

An **ammeter** is an instrument used to measure the electric current flowing through the circuit.

Do's and Don'ts of Ammeter

Before taking any reading, teachers-in charge/laboratory technicians should observe the following (Do's):

- test the ammeter to see if it allows current to pass through by observing deflection when the circuit is complete or closed;
- connect the ammeter in series with a resistor;
- make sure you have different values of resistors since an ammeter may not work if the resistor is too high or too low;
- start testing different ammeters by taking readings using the same resistor;
- compare values of the current reading of every ammeter;
- ammeters with approximately the same reading should be considered during laboratory preparation; and
- ammeters with a very high deviation from the standards should not be included in your list.

Note: Ammeters may not give values because of internal resistance of the cell and resistance of connecting wires. As such, ammeters giving approximate values should be selected.

Don'ts of Ammeter

- Check the proportionality of the source, resistor, and ammeter to protect the ammeter.
- Do not use an exhausted source of e.m.f. or dry cell.

Voltmeter

Voltmeter is an instrument for measuring the voltage drop across the external resistor.

Do's of Voltmeter

Before taking any measurement, teachers in charge/laboratory technicians should observe the following (Do's):

- (i) test whether the voltmeter to see if is conducting by observing deflection when the circuit is complete;
- (ii) connect the Voltmeter across the dry cell; and
- (iii) select the Voltmeter which gives the same reading.

Multimeter

A digital **multimeter** is a **test tool for measuring two or more electrical values**, principally voltage (volts), current (amps), resistance (ohms) and continuity. It is a standard diagnostic tool for technicians in the laboratory (see Figure 4).

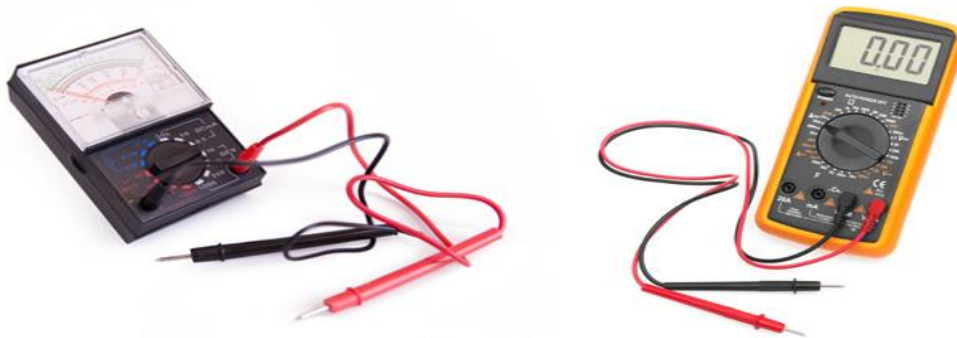

Figure 4

How to use a Multimeter?

A multimeter consists of three main parts: The **display**, **selection knob** and **ports**. Figure 5 is illustrative.

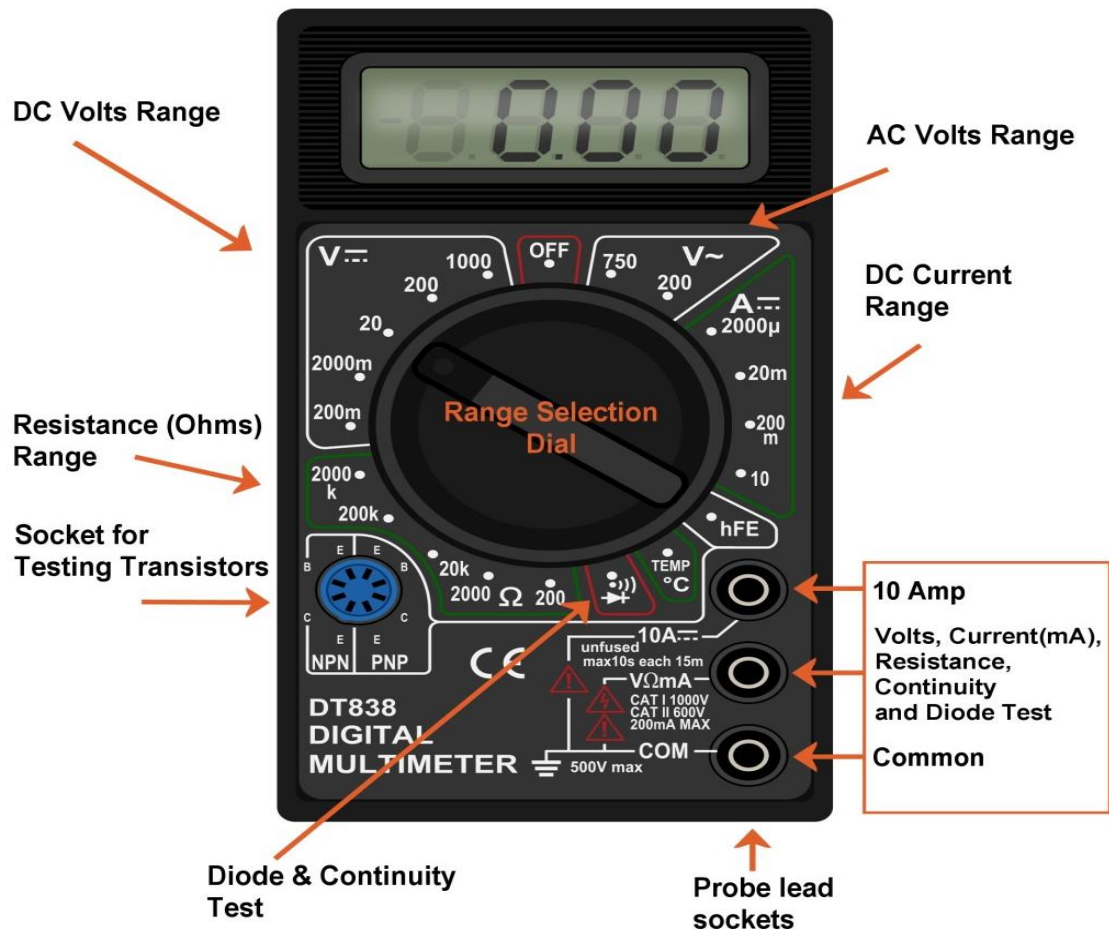

Figure 5

- The **display** usually has four digits with the ability to display a negative sign.
- The **selection knob** allows the user to set the multimeter to read different SI units such as milliamps (mA) of the current, voltage (V) and resistance (Ω).
- Two probes are plugged into two of the **ports** on the front of the unit. **COM** stands for common and is always connected to the Ground or '-' of a circuit. The **COM** probe is conventionally black but there is no difference between the **red probe** and the **black probe** other than colour.
- **10A** is a special port for measuring large currents (greater than 200 mA).
- **V Ω mA** is a port that the red probe is conventionally plugged into. This port allows the measurement of current (up to 200 mA), voltage (V), and resistance (Ω). The probes have a *banana* type connector on the end that plugs into the multimeter. Any probe with a banana plug will work with this meter. This meter allows different types of probes to be used.

(a) **Measuring Voltage**

Suppose you want to measure voltage on an AA battery:

- plug the black probe into **COM** and the red probe into **mAV Ω** ;
- set the multimeter to "20V" in the DC (direct current) range. Almost all the portable electronics use **direct current** and not **alternating current**;
- connect the black probe to the battery's ground or '-' and the red probe to power or '+'.

- (iv) apply a little pressure by squeezing the probes against the positive and negative terminals of the AA battery; and
- (v) if you have a fresh battery, it should be one with a reading of around 1.5 V on the display indicating that this battery is brand new, so its voltage is exactly 1.5 V or slightly higher than that as displayed in Figure 6:

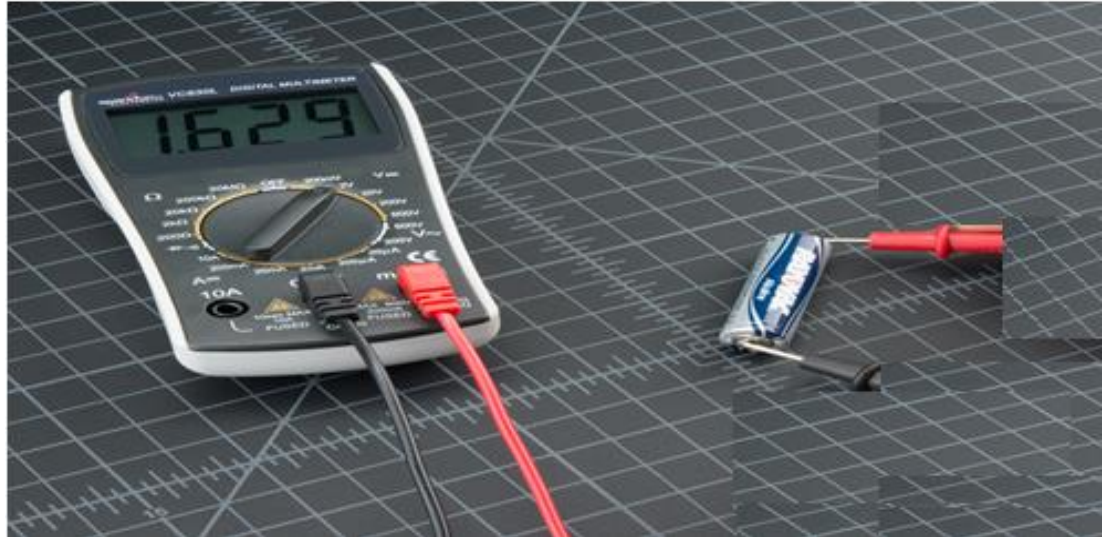

Figure 6: The value of voltage V on an AA battery

Note:

- (i) If you are measuring DC voltage (such as a battery or a sensor hooked to an Arduino), you should set the knob at a point where the V has a straight line. Figure 7 is illustrative:



Figure 7: Use V with a straight line to measure DC Voltage

- (ii) If you are measuring AC voltage, it is recommended that you should get a non-contact tester rather than using a multimeter. AC voltage (like what comes out of the wall) can be dangerous, so you rarely need to use the AC voltage setting (the V with a wavy line next to it) as Figure 8 illustrates:



Figure 8: Use V with a wavy line to measure AC Voltage

What happens if you switch the red and black probes?

The reading on the multimeter is simply negative. Nothing bad happens! The multimeter measures voltage in relation to the common probe. How much voltage is there on the ‘+’ of the battery compared to the common or the negative pin? 1.5V. If we switch the probes, we define ‘+’ as the common or zero point. How much voltage is there on the ‘-’ of the battery compared to our new zero? -1.5 V. Figure 9 is illustrative:

4.0 AREAS OF ASSESSMENT

Thorough analysis has been done on the syllabuses for CSEE, ACSEE and DSEE to identify the assessment areas. These three levels assess the candidates’ ability and skills in performing experiments to determine the values of different quantities and to verify physical phenomena. When an experiment is done, the criteria for assessing the experimental data will be considered. If graph/s is/are to be plotted, then all the basic requirements of a graph, that is, title, scales, axes, best line/curve, slope indication and transfer of points will be considered. Table 2 indicates the level at which each area/topic is assessed:

Table 2: Level of assessment for each topic/area

S/n.	Topic/Area of Assessment	Levels of Assessment		
		CSEE	ACSEE	DSEE
1.	Measurement	✓	X	X
2.	Archimedes Principle and Law of Flotation	✓	X	X
3.	Structure and Properties of Matter	✓	✓	✓
4.	Forces in Equilibrium	✓	✓	X
5.	Motion in a Straight line	✓	✓	✓
6.	Friction	✓	X	X
7.	Simple Harmonic Motion	X	✓	✓
8.	Rotation of Rigid Bodies	X	✓	X
9.	Fluid Dynamics	X	✓	✓
10.	Light	✓	✓	X
11.	Heat/ Measurement of Thermal Energy	✓	✓	✓

12.	Vibrations and Waves	✓	✓	✓
13.	Current Electricity	✓	✓	✓

NB: ‘**Tick**’ indicates ‘assessed’ and ‘**cross**’ refers to ‘not assessed’.

4.1. Measurement

Measurement is an act of determining a target’s size, length, weight, capacity or other aspects. Competence in using measurement tools correctly is very important. Measurement is done by a worker who is competent in using the measurement tools whereas instrumentation is carried out by a technician. An example of measurement is using a ruler to determine the length of a piece of paper. Under this topic, candidates will practically be assessed on how to measure and express quantities in correct decimal places and significant figures. However, they should also be examined on solving experimental and numerical problems in measurement.

Specific objectives

- Determination of the density of regular, irregular and insoluble substances.
- Determination of the relative density of solids and liquids.
- Verifying Archimedes Principle.
- Applying Archimedes Principle to determine the relative density of fluids.

Apparatuses and Materials

When a checklist is sent to schools/colleges, teachers in charge/laboratory technicians are required to make sure that all the apparatuses and materials listed are available. Under this topic, the following list of apparatuses and materials should be prepared:

Stones of different masses (at least five stones of the same nature), measuring cylinders of different capacities, reel of cotton thread/inextensible string, triple balance/beam balance/digital balance, beakers of different capacities, eureka can, water, relative density bottle of different capacities, sand or lead shots, gravel (stone), spring balance, blocks of wood and pieces of metal, slotted masses of different masses, cotton wool, test-tubes, standard masses of different masses, kerosene, oil (engine/cooking oil), alcohol, coins, and plasticine.

Sample Question 1: Determination of density of an irregular solid.

Apparatuses and Materials

Apart from the normal laboratory fitting, teachers in charge/laboratory technicians should prepare the following apparatuses in each set of the experiment.

Pieces of stones of different masses (at least five stones of the same nature), a measuring cylinder of about 50 ml, 5 pieces of cotton thread about 30 cm long, a triple balance/beam balance, a beaker of about 100 ml, eureka can, and water.

Procedures

- Measure the mass m of pieces of a stone using a beam balance.
- Tie each piece of stone using a thread.

- (c) Place the measuring cylinder under the spout of the eureka can.
- (d) Fill the eureka can with water until it overflows through the spout. Allow the overflowing water to run until the last drop.
- (e) Set the apparatus as shown in Figure 13:

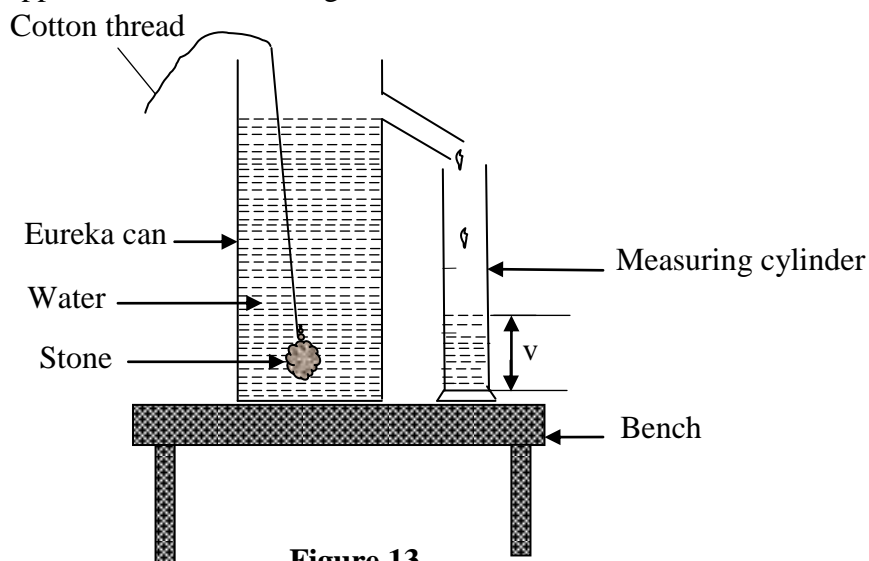

Figure 13

- (f) Carefully lower the stone of the smallest mass into the eureka can until it is wholly immersed in the water and record the volume v of the displaced water.
- (g) Repeat procedure (f) for other four masses in increasing/ascending order.
- (h) Tabulate the results.
- (i) Plot a graph of v against m .
- (j) Determine the slope of the graph.
- (k) What is the physical meaning of the slope?
- (l) Calculate the density of the stone.

Discussion

The mass of a solid can be measured on a beam balance. The volume of an irregular solid cannot be determined by direct measurement. However, when an object is fully submerged/immersed in a liquid, it occupies a volume which is equal to that of the displaced liquid. Therefore, the density of an irregular solid is determined when the mass of the solid is divided over the volume of the displaced liquid.

Sample Question 2: Determination of relative density of a substance.

Apparatuses and materials

Apart from normal laboratory fittings, teachers in charge/laboratory technicians should provide the following apparatuses to each candidate:

A measuring cylinder of about 50 ml, thin threads, a beaker of about 100 ml, gravel (stone), water and eureka can, triple balance/beam balance.

Procedures

- (a) Measure the mass m_0 (g) of a stone using a beam balance.

- (b) Fill the eureka can and let water overflow until the last drop.
- (c) Place a clean dry beaker of mass m_1 (g) under the spout of the overflow can.
- (d) Lower the stone slowly with a thin thread until it is totally immersed.
- (e) Obtain the mass of beaker using the water overflowed from the Eureka can as m_2 (g).
- (f) Use a measuring cylinder to measure the volume of water that has overflowed into the beaker.
- (g) Record the results as follows:
 - Mass of stone = m_o (g);
 - Mass of beaker = m_1 (g);
 - Mass of beaker with water = m_2 (g); and
 - Mass of water only = $(m_2 - m_1)$ g
- (h) Apply the relation, Relative density of a stone

$$= \frac{\text{mass of a stone}}{\text{mass of an equal volume of water}}$$

$$\text{Relative density of a stone} = \frac{m_o}{m_2 - m_1}$$

Discussion

Relative density is a physical property of solids and liquids. To determine the relative density of a solid experimentally, we must measure the mass of the solid, the mass of beaker and the mass of beaker with water using a beam balance. Then obtain the mass of an equal volume of water by recording the difference between the mass of the beaker with water and the mass of the beaker. The amount of water displaced by the solid when immersed in water is collected by a beaker from the spout of the eureka can. The volume of the water displaced is measured using a measuring cylinder. After collecting the experimental data, the relative density of a solid can be calculated by dividing the mass of the solid to the mass of an equal volume of water.

4.2. Archimedes Principle and Law of Floatation

This physical law of buoyancy was discovered by ancient Greek mathematician and inventor Archimedes. The principle states: “**A body completely or partially immersed in a fluid experiences an upthrust which is equal to the weight of the fluid displaced**”. Archimedes’ principle is very useful in determining the weight of an object when partially or completely immersed in a fluid. It also helps to determine volume of an object that does not have a regular shape.

When an irregular object is submerged, the weight of the fluid displaced is equal to the force acting on the object in the fluid. This method can also be used to calculate the density or specific gravity (relative density) of an object, and to determine the volume of irregular objects.

In this area, students will be assessed in CSEE on how to relate the weight of a displaced fluid and the apparent loss in weight. They should attempt both numerical and theoretical approaches pertaining to Archimedes Principle.

Apparatuses and materials

Spring balances (0 -10 N), Loads of different masses e.g. 50 g,100 g,150 g, 200 g and 250 g, Beakers (50 ml -100 ml), measuring cylinders, eureka can (250 ml), fluids, beam balances and cotton threads.

Sample question 1: Verification of the Archimedes Principle.

Apparatuses and Materials

Apart from the normal laboratory fittings, teachers in charge/laboratory technicians should prepare the following apparatuses for each set of the experiment:

spring balances (0-10 N), loads of masses 50g, 100g, 150g, 200g and 250g, Beakers (50 ml-100 ml), measuring cylinders, eureka can (250ml), water, beam balances, and cotton threads.

Procedures

- (a) Set up the apparatus as shown in Figure 14.

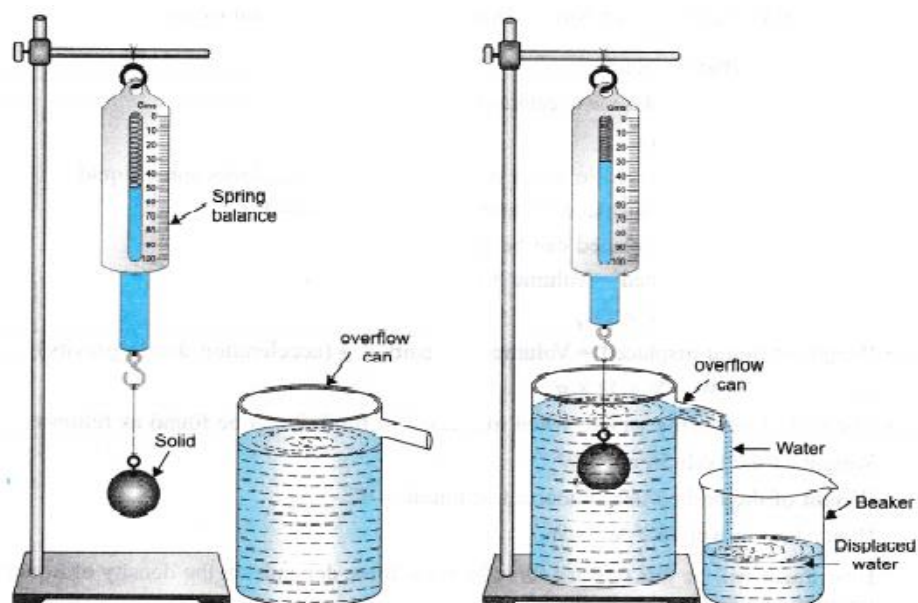

Figure 14

- (b) Take one of the solid blocks and weigh it by hanging it on the hook of the spring balance using a thread. Find the weight of the solid in air W_1 and note it.
- (c) Take a 250ml beaker, weigh it on a balance and note down its mass m_1 .
- (d) Take the overflow can and fill it with water to the brim of the outlet and place the beaker below the overflow outlet of the can to collect the displaced water. Now, start lowering the metallic block (S_1), still attached to the spring balance, into the water of the overflow can.
- (e) Note down the loss of weight of the metallic block as it gets completely immersed in water W_2 . Weigh the beaker with the displaced water and note down the mass m_2 .
- (f) Find the mass of the displaced water $m_2 - m_1$.
- (g) Calculate the upthrust, $\Delta W = (m_2 - m_1)g$.

- (h) Compare the apparent loss of weight of the solid in water with the weight of the amount of water displaced.
- (i) Comment on your results.

Sample question 2: Determination of relative density of a liquid using the Archimedes Principle.

Apparatuses and Materials

Apart from the normal laboratory fittings, teachers in charge/laboratory technicians should prepare the following apparatuses for each set of the experiment:

Spring balance (0 - 10 N), two beakers, masses of mass 50 g, 100 g, 200 g and 250 g, water and Liquid X.

Procedures

- (a) Take a 50 g mass and call it m_1 and weigh in air using a spring balance. Note the weight W_1 .
- (b) Immerse m_1 totally in water contained in a beaker and record its apparent weight W_2 .
- (c) Remove m_1 in water and immerse it in a liquid X contained in another beaker or cylinder. Record its apparent weight W_3 .
- (d) Repeat the experiment by varying the values of the masses up to five different values in order of 50g mass. Figure 15 is illustrative:

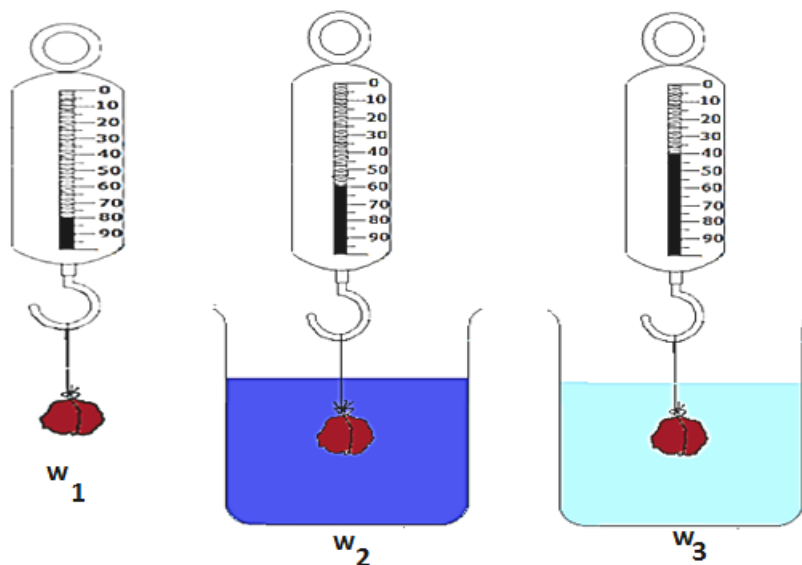

Figure 15

- (e) Tabulate your results as shown in the following table:

Mass (g)	$W_1(N)$	$W_2(N)$	$W_3(N)$	Upthrust in water, $U_w=(W_1-W_2)$	Upthrust in Liquid X, $U_x=(W_1-W_3)$
50					
100					
150					
200					
250					

- (f) Plot the graph of U_x against U_w .
- (g) Deduce the slope of the graph.
- (h) What is the physical meaning of the slope?

Discussion

We can simply find the slope, which is the ratio of upthrust of Liquid X to the upthrust of water. The outcome is the relative density of the liquid.

4.3. Structure and Properties of Matter

The characteristics of materials are functions of their atomic and molecular structures. Their properties such as **elasticity**, **rigidity**, **ductility** and **plasticity** allow us to distinguish between substances and classify them accordingly, thus revealing the identity of unknown substances. Elasticity is the ability of a deformed material body to return to its original shape and size when the forces deforming it are removed. A body with this ability behaves or responds elastically.

To a greater or lesser extent, most of the solid materials exhibit elastic behaviour, but there is a limit to the magnitude of the force and resultant deformation within which the elasticity recovery is possible for any given material. This limit is called elastic limit, which is the maximum stress or force per unit area within a solid material that can arise before the onset of a permanent deformation. Stress beyond the elastic limit causes a material to yield or flow. For such materials the elastic limit marks the end of elastic behaviour and the beginning of plastic behaviour. For most brittle materials, stresses beyond the elastic limit result in fracture with almost no plastic deformation.

Surface tension is a property of the surface of a liquid that allows it to resist an external force to happen due to the cohesive nature of its molecules. The cohesive forces between liquid molecules are responsible for the phenomenon known as surface tension. The Young's modulus (E) is a property of the material that tells us how easily it can stretch and deform. It is defined as the ratio of tensile stress (s) to tensile strain (e). Where stress is the amount of force applied per unit area ($s = \frac{F}{A}$) and strain is the extension per unit length ($e = \frac{dl}{l}$). General, Young's

$$\text{modulus, } E = \frac{s}{e} = \frac{F/A}{dl/l}$$

Specific objectives

- Justification of the relationship between tension and extension of an elastic material when loaded.
- Determination of the coefficient of surface tension of various liquids.
- Distinguish among the moduli of elasticity.

Apparatuses and materials

Apart from the common fittings found in the laboratory, teachers in charge/laboratory technicians are required to prepare apparatuses and materials based on the checklist provided. Specifically, the experiments conducted under this topic should include the following apparatuses and materials:

Retort stands, helical/spiral springs of different spring constant, rubber bands, scale pans, pointers, meter rule, measuring balance/beam balance, pieces of wires, vernier callipers, slotted masses of different masses, micrometer screw gauge, spring balance, and stopwatches.

Sample Question 1: Verification of Hooke’s Law and determination of spring constant of spiral spring.

Apparatuses and materials

Apart from the normal laboratory fittings, teachers in charge/laboratory technicians should prepare the following apparatuses and materials for each set of the experiment:

1 retort stand, 1 helical/spiral spring stretchable by minimum mass of 100 g, 1 rubber band, 1 scale pan, 1 pointer, 1 meter rule, 1 measuring balance/beam balance, 5 pieces of hooked brass each of 100 g.

Procedures

- Attach a pointer at the lower end of unloaded spiral spring suspended vertically. Place a scaled metre ruler in an upright position with a zero mark at the top behind the pointer and note down the reading, x_0 (cm).
- Attach a hooked brass of 100g at the end of the spring and record the new reading, x (cm) on the metre ruler.
- Repeat the procedure (b) for masses of 200 g, 300 g, 400 g and 500 g.
- Prepare a table of results as indicated in the following table:
 $x_0 = \dots$ (cm).

Mass hang on the spring (kg)	Stretching force (N)	Scale reading (cm)	Extension of spring (cm)	$\frac{\text{Stretching force}}{\text{Extension}}$

- Plot a graph of stretching force against extension.
- Determine the slope of the graph.
- Compute the average of the values of the last column of the table.
- Compare the average value obtained in part (g) with the slope obtained in part (f).
- Calculate the spring constant.

- (j) Comment with reason (s) regarding whether Hooke's Law has been obeyed.

Discussion

Hooke's Law is obeyed by all substances if they remain within their elastic limit. The law states that within the elastic limit, the extension of a spring is directly proportional to the force applied provided that the elastic limit is not exceeded. The experiment has found that the ratio (stretching force/extension), is nearly constant, that is stretching force = spring constant \times extension. The plotted graph of the stretching force against extension is a straight line showing that the stretching force of a spiral spring is directly proportional to the extension which portrays Hooke's Law.

Sample question 2: Determination of surface tension of a liquid.

Apparatuses and materials

Apart from the normal laboratory fittings, teachers in charge/laboratory technicians should prepare the following apparatuses and materials for each set of the experiment:

Viscous liquid, funnel/burette with tap, measuring cylinder of about 20 ml, Beam balance, clip/Hoffman clamp, and retort stand with its accessories.

Procedures

- (a) Using a beam balance, measure the mass m of an empty measuring cylinder.
(b) Set the apparatuses as shown in Figure 16:

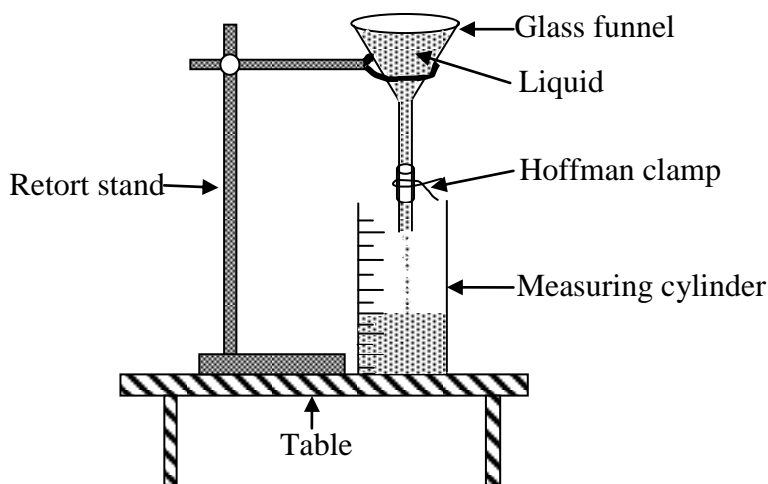

Figure 16

- (c) With the hoffman clamp closed, fill the funnel with the liquid provided.
(d) Adjust the hoffman clamp on the funnel to allow drops of liquid to pass.
(e) Read the initial volume V_0 (ml) of the liquid in the measuring cylinder.
(f) Allow and count about $N = 100$ drops in the measuring cylinder and read new volume V (ml).
(g) While adding more liquid into the funnel, repeat the procedure in part (f) by allowing $N = 25$ drops into the cylinder each time and recording the new volume V (ml).to obtain five more readings.
(h) Measure the mass of the measuring cylinder with its content.

- (i) Tabulate your results including the values of $V - V_0$.
- (j) Plot the graph of $V - V_0$ against N and determine its slope, S .
- (k) Determine the density, ρ of the liquid.

(l) Compute the surface tension, σ of the liquid from the equation,
$$\sigma = \frac{4\pi r^2 \rho g S^2}{6\theta} \frac{1}{1.9}$$
.

Discussion

Surface tension is caused by the effects of intermolecular forces at the interface. It depends on the nature of the liquid, the surrounding environment, and temperature. Liquids where molecules have large attractive intermolecular force will have a large surface tension. Surface tension is the property of liquid associated with the imbalance of molecular forces on the surface of the liquid. Factors causing the change in molecular forces also affect the surface tension.

The coefficient of the surface tension of a liquid is the force acting on the surface of the liquid at right angles to the line of unit length of the surface of the liquid. However, the following precautions should be considered:

- Presence of impurities in the liquid can alter the surface tension.
- Throughout the experiment, make sure you maintain the position of the adjusted Hoffman clamp to keep the size of liquid drop constant.
- The surrounding temperature should be approximately constant throughout the experiment.

Note: In many applications, one can decrease or increase the surface tension. This can be done by changing factors that affect surface tension. For example, surfactants are added to water so that dirt can be easily removed from clothes.

Sample question 3: Determination of Young’s modulus from a period of vibration of a loaded metre rule.

Apparatuses and materials

Apart from the normal laboratory fittings, teachers in charge/laboratory technicians should prepare the following apparatuses and materials for each set of the experiment: G-clamp, wooden metre rule, standard mass of 100 g, and stopwatch.

Procedures

- (a) Using a micrometre screw gauge, measure the width b and thickness d of a metre ruler.
- (b) Clamp firmly the loaded wooden metre rule to the edge of the bench by G-clamp with length, $l = 70$ cm projected from it as shown in Figure 17:

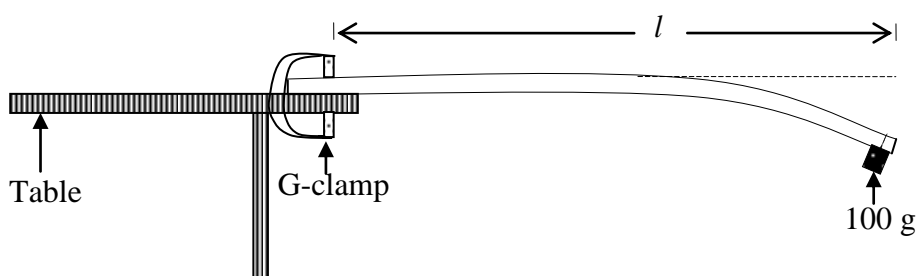

Figure 17

- (c) Let the wooden metre ruler vibrate to obtain periodic time T by timing 10 vibrations.
- (d) Repeat the procedures in parts (b) and (c) by reducing the length, l by 5 cm to obtain four other readings.
- (e) Tabulate your results including the values of T^2 and l^3 .
- (f) Plot a graph of T^2 against l^3 and determine its slope.
- (g) Determine Young's modulus, E of the material from equation, $\frac{\pi^2}{b} = 0.625ET^2 \frac{ad^3}{Cl^3}$.

Discussion

Young's modulus equation is $E = \frac{\text{Tensile stress}}{\text{Tensile strain}} = \frac{FL}{A \Delta L}$, where F is the applied force, L is the initial length, A is the cross-section area, and E is Young's modulus in Pascal (Pa). Using a graph, one can find out whether a material shows elasticity or not. Young's modulus of a material is a useful in predicting the behaviour of the material when subjected to a deforming force. The knowledge of elasticity is important in daily practices including construction of building and construction bridge and designing of vehicle.

4.4. Forces in Equilibrium

An object is in a state of equilibrium when all the forces acting upon it are balanced. The change of the state of a body appears in several forms. The most common form is the turning effect which is called **moment of a force**. The moment of force about a point is the turning effect of the force about that point. The magnitude of the turning effect is numerically equal to the product of the force applied and the perpendicular distance from its point of application. The equilibrium state of a body is brought about by the following two conditions:

- (a) The sum of clockwise moment should be equal to the sum of anticlockwise moment about the turning point.
- (b) The sum of upward forces acting on the body should be equal to the sum of downward forces.

Specific objectives

- Verification of the Principle of Moments.
- Determination of the centre of gravity and mass of a regular shaped body.

Apparatuses and materials

When a checklist is sent to schools/colleges, teachers in charge/laboratory technicians are required to make sure that all the apparatuses and materials listed are available. Under this topic, the following list of apparatuses and materials should be prepared:

Wooden metre ruler/metal rod/wooden rod, standard masses of different masses, knife edge, wooden blocks of 20 cm × 10 cm × 7 cm, cotton threads, beam balance, vernier calliper, and scale pan/mass hanger.

Sample Question: Determination of unknown standard mass x by applying the Principle of Moments.

Apparatuses and Materials

Apart from the normal laboratory fittings, teachers in charge/laboratory technicians should prepare the following apparatuses for each set of the experiment:

Wooden metre ruler/metal rod/wooden rod, standard mass of 100 g, knife edge, wooden block of 20 cm × 10 cm × 7 cm, two pieces of cotton threads each of 20 cm, beam balance, unknown mass x (40 g to be hidden).

Procedures

- Determine the centre of mass G of the wooden metre ruler by placing it on the knife edge until it balances horizontally. Use a pencil to mark on the balance point of your wooden metre ruler.
- Suspend an unknown mass x (g) on the left hand-side of your wooden metre ruler and a mass m of 100 g at a length b , equal to 10 cm from the knife edge on the right hand-side.
- Adjust the position of x until the ruler balances in a horizontal position as shown in Figure 18:

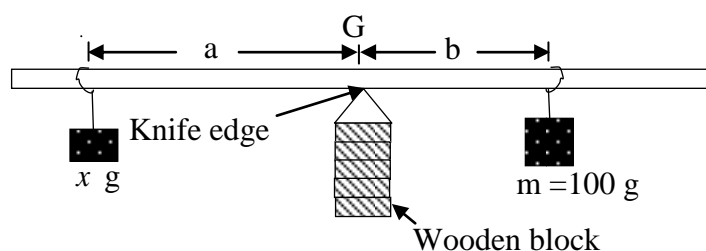

Figure 18

- Read and record length “a” and “b” as shown in Figure 18.
- Move the mass m to the right each time by a length of 2.5cm. Then adjust mass x on the left until the wooden metre ruler balances.
- Repeat the procedure (e) to obtain four more readings.
- Tabulate your results.
- Plot a graph of “b” against “a” and determine its slope, s .
- Compute the value of x from equation, $x = sm$.
- What does x represent?

Discussion

The moment of force about a point is, by definition, a force × perpendicular distance from the point. It is described as clockwise or anticlockwise depending on the direction of its turning effect. The relationship between the moment of force, which keeps a pivoted object in equilibrium leading to the Principle of Moments, which states: ***When a body is in equilibrium under the action of a number of forces, the sum of the clockwise moments is equal to the sum of the anticlockwise moments.***

4.5. Motion in a Straight line

The force of gravity and acceleration are always directed downward towards the earth. This type of motion is called free-fall its acceleration is caused by gravity g . Objects falling under the influence of gravity are examples of objects moving with constant acceleration. One way in which the value for the acceleration due to gravity can be determined is by observing the motion of a simple pendulum.

Specific objective

- Determination of the acceleration due to gravity, g .

Apparatuses and materials

When a checklist is sent to schools/colleges, teachers in charge/laboratory technicians are required to make sure that all the apparatuses and materials listed are available. Under this topic, the following list of apparatuses and materials should be organised:

Calibrated stopwatches, retort stand with clamps, two wooden parts each of $5\text{ cm} \times 3\text{ cm} \times 1\text{ cm}$ or rubber cork split into two halves, pendulum bobs, inextensible string/thread, and metre rulers.

Sample Question: Determination of the acceleration due to gravity by means of a simple pendulum.

Apparatuses and Materials

Calibrated stopwatch, retort stand with its clamp, two wooden parts each of $5\text{ cm} \times 3\text{ cm} \times 1\text{ cm}$ or rubber cork split into two halves, pendulum bob, inextensible string/thread, metre rule

Procedures

- (a) Tie a piece of thread to the pendulum bob.
- (b) Fix the free end of the thread between the pads with the help of the retort stand and the clamp.
- (c) Ensure that the length of the thread from the fixed point to the bob is about 90 cm as shown in Figure 19:

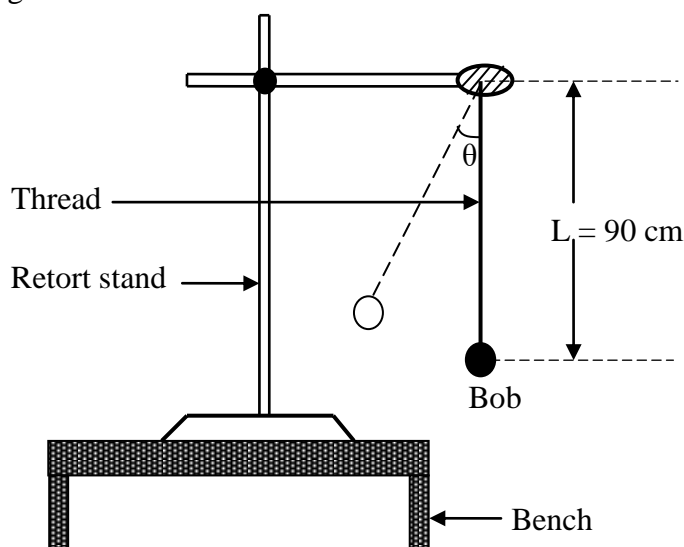

Figure 19

- (d) Pull the bob aside at a small angle θ and then release it to oscillate in a to-and-fro motion and immediately start the stopwatch. Read and record the time (t) for 20 complete oscillations and, finally, find its periodic time, T.
- (e) Repeat procedures (c) and (d) with the length, L (cm) of 80, 70, 60, 50, 40 and 30.
- (f) Tabulate your results including the column for L, t, T and T^2 .
- (g) Plot a graph of L against T^2 .
- (h) Calculate the slope of the graph.
- (i) Use the slope calculated in (h) and the equation, $T=2\pi\sqrt{\frac{L}{g}}$, to calculate the acceleration due gravity, **g**.

Discussion

With the assumption of small angles, the frequency and period of the pendulum are independent of the initial angular displacement. All simple pendulums should have the same period regardless of their initial angle and masses.

The period **T** for the simple pendulum depends on the length, **L** of the string according to the equation, $T=2\pi\sqrt{\frac{L}{g}}$.

4.6. Friction

Friction can be defined as the force that resists the relative motion of solid surfaces, which are sliding against each other. There are mainly three types of friction: **Dry friction**, **Fluid friction** and **internal friction**. However, this experiment will examine dry friction only. Dry friction occurs when two solid surfaces are in convention if there is a tendency of sliding.

However, dry friction is split into two sub-frictions: **Static** and **dynamic**. Commonly, dynamic frictional force will be less than the static frictional force (limiting friction). This static frictional force is given by $f_s = \mu_s R$, while kinetic frictional force is $f_k = \mu_k R$, where μ_s and μ_k are coefficients of the static friction and kinetic friction, respectively and R is the normal reaction.

Static friction exists between two surfaces in contact when there is relative motion between them. The coefficient of static friction, μ_s is the ratio of the limiting frictional force to the normal reaction. However, the coefficient of kinetic friction, μ_k is defined as the ratio of the kinetic friction to normal reaction. Also, kinetic friction is the friction that exists between two surfaces in contact moving relative to each other.

Specific objective

- Determination of the coefficient of friction.

Apparatuses and materials

When a checklist is sent to schools/colleges, teachers in charge/laboratory technicians are required to make sure that all the apparatuses and materials listed are available. For this topic, the following list of apparatuses and materials should be prepared:

Pieces of wood (4 cm × 3 cm × 2 cm), wooden blocks (20 cm × 10 cm × 7 cm) with hook, scale pans/mass hanger, light inextensible strings, spring balance, simple frictionless pulleys, standard masses of different masses, wooden board (60 cm × 20 cm × 2 cm).

Sample Question 1: Determination of the coefficient of static friction, μ_s .

Apparatuses and materials

Apart from the normal laboratory fittings, teachers in charge/laboratory technicians should prepare the following apparatuses for each set of the experiment:

Four slotted masses each of 100 g, a wooden block (20 cm × 10 cm × 7 cm) with hook, wooden board (60 cm × 20 cm × 2 cm), a scale pan/mass hanger, a light inextensible string of 50 cm, a spring balance, a simple frictionless pulley, standard masses of 2 g, 10 g, 50 g, 100 g and 200 g.

Procedures

- (a) Set up the apparatus as shown in Figure 20:

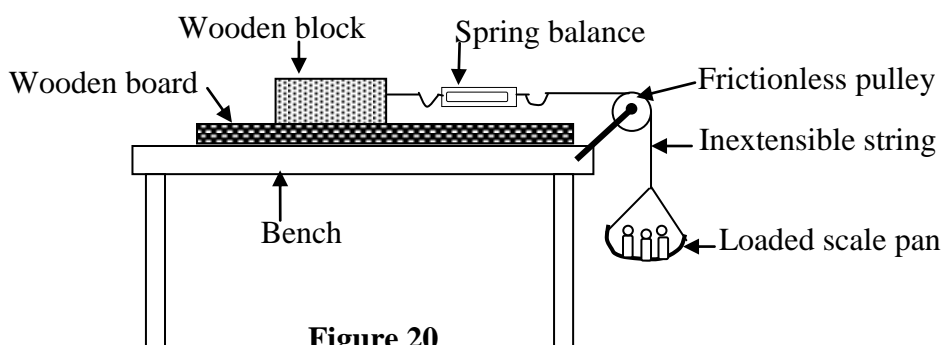

- (b) Measure the mass (m) of a wooden block with a hook.
(c) Place the wooden block with the hook on a frictional wooden board.
(d) Attach a spring balance to the hook and the free end of the spring balance. Tie the string which passes over a frictionless pulley as shown in Figure 20.
(e) Attach a loaded scale pan to the other free end of the string.
(f) Place masses on the scale pan until the wooden block starts moving, then record the reading on the spring balance as static friction, f_s .
(g) Add 100 g mass on top the wooden block and then put some masses on the scale pan until block with 100 g starts to slide (move) and then record the reading on the spring balance as f_s .
(h) Repeat part (g) for 200g 300 g, 400 g and 500 g.

- (i) Tabulate your results as shown in the following table:

Mass, m (wooden block + slotted mass) kg	Normal reaction, $R = mg$ (N)	Static friction f_s (N)

- (j) Plot a graph of the static friction, f_s against the normal reaction, R .
(k) Determine the gradient of the graph.
(l) What is the significance of the gradient of the graph?
(m) What happens to static friction as the total mass on the wooden board increases?

Discussion

Static friction is a self-adjusting force because it comes into action when the body is lying over the surface of another body without any motion, that is, it does not have any fixed magnitude or a fixed direction, but it will adjust according to the force applied. When that body overcomes the force of static friction, the maximum value of static friction, known as **limiting friction**, is reached. Limiting friction is directly proportional to the normal reaction. As weight = normal reaction, and applied force = force of friction, force of friction \propto normal reaction, that is $f_s \propto R$. Similar results are obtainable when more blocks are used in this experiment.

4.7. Simple Harmonic Motion

Periodic motion refers to motion with which an object that regularly returns to its given position after a fixed time interval. **Simple harmonic motion** is a special kind of periodic motion in which the object oscillates sinusoidally and smoothly. It arises whenever an object returns to the equilibrium position by a restoring force which is proportional to the object's displacement, $F = -kx$.

The equation, $F = -kx$ is a mathematical implication of Hooke's Law, which describes the restoring force of an oscillating spring of stiffness **k** (spring constant).

The back-and-forth movements of the swing against the restoring force are **simple harmonic motion**. The pendulum oscillating back and forth from the mean position is an example of simple harmonic motion. Another example of simple harmonic motion is **Bungee Jumping**.

Specific objectives

- Determination of acceleration due to gravity, **g**.
- Determination of spring constant of a spring.
- Determination of effective mass of the spring.

Apparatuses and materials

When a checklist is sent to schools/colleges, teachers in charge/laboratory technician are required to make sure that all the apparatuses and materials listed are available. Under this topic, the following apparatuses and materials should be prepared:

Calibrated stopwatches/clocks, retort stand with clamps, two wooden pads each of 5 cm \times 3 cm \times 1 cm or rubber cork split into two halves, pendulum bob, inextensible string/thread, metre rules, standard masses of different masses, scale pans, hanger and spiral/helical springs.

Sample Question 1: Determination of the acceleration due to gravity at your school by means of a simple pendulum.

Apparatuses and materials

When a checklist is sent to schools/colleges, teachers in charge/laboratory technicians must make sure that all the apparatuses and materials listed are available. For this topic, the following list of apparatuses and materials should be organised:

Calibrated stopwatch, retort stand with its clamps, two wooden pads each of 5 cm × 3 cm × 1 cm or rubber cork split into two halves, pendulum bob, inextensible string/thread, and a metre ruler.

Procedures

- (a) Tie a thread to the given pendulum bob as shown in Figure 21. Make a knot of 10cm from the bob.

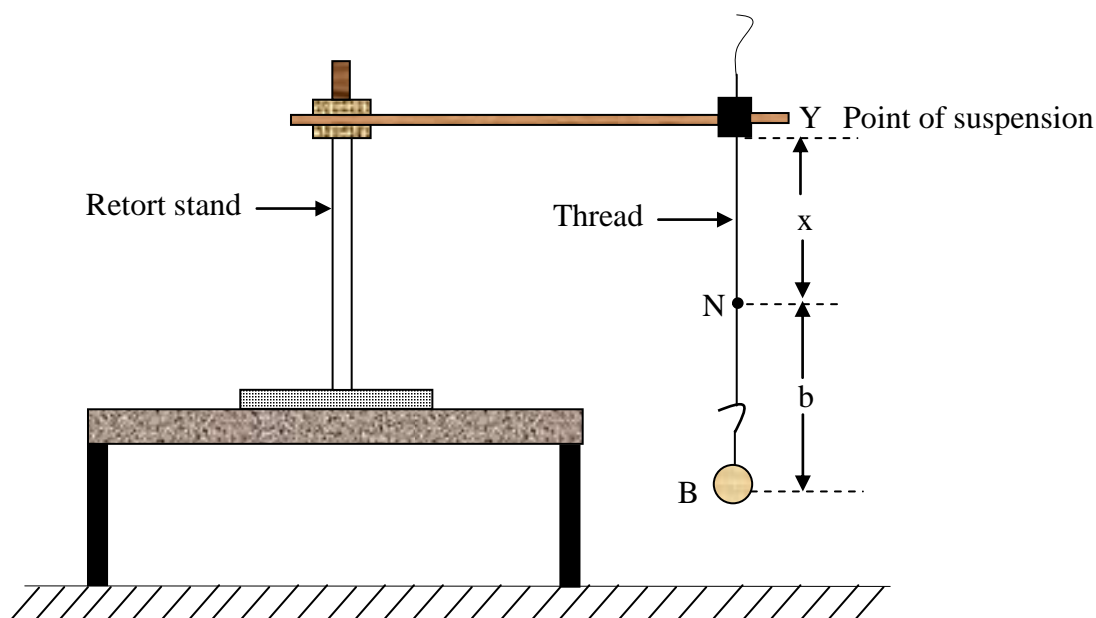

Figure 21

- (b) Measure and record the distance b , between the knot N and the pendulum bob B .
- (c) Adjust x to be 10 cm, displace the pendulum by a small angle and then release it so that it swings to and from with a small amplitude of vibration.
- (d) Find the time t for 30 oscillations and determine the periodic time T for one oscillation.
- (e) Repeat procedures (c) to (d) for values of $x = 20, 30, 40, 50$ and 60 cm.
- (f) Tabulate the values of x, t, T , and T^2 .
- (g) Plot a graph of T^2 against x .
- (h) Find the slope of the graph.
- (i) Determine the value of the acceleration due to gravity g given that $T^2 = 4\pi^2 \frac{x+b}{g}$.
- (j) Read and record the value of intercept along the horizontal axis.
- (k) What is the physical significance of the intercept along x -axis in (j)?
- (l) Explain two possible sources of errors and precautions taken in this experiment.

Sample Question 2: Determination of spring constant of a spiral spring.

Apparatuses and materials

When a checklist is sent to schools/colleges, teachers in charge/laboratory technicians should make sure that all the apparatuses and materials listed are available. For this topic, the following list of apparatuses and materials should be prepared:

Spiral springs, a metre ruler, scale pan (hanger), retort stands with its clamp, slotted masses of 200 g and 300 g, a hook to suspend the spring, and digital beam balance.

Procedures

- Clamp the spring on the retort stand.
- Attach the scale pan at the end of the spring.
- Put mass, M_1 of 200g onto the scale pan, then pull the spring through a small distance and release it.
- Record the time for 10 oscillations and determine the periodic time T_1 .
- Repeat the procedure for another mass, M_2 of 300 g and find its periodic time T_2 .
- Determine the spring constant K using the relation $K = 4\pi^2 \left(\frac{M_2 - M_1}{T_2^2 - T_1^2} \right)$.

Discussion

If a mass 'm' is hung from the end of a vertically suspended spiral spring, it stretches by a length e . At this point, the body is assumed to be at equilibrium. If the body is further pulled by distance x downward and is released, it executes simple harmonic motion.

For an ideal massless spring that obeys Hooke's law, the time required to complete an oscillation T (s) depends on the spring constant and the mass m , of an object hung at one end:

Therefore, the period of oscillation can be calculated using the formula $T = 2\pi\sqrt{\frac{M}{K}}$ which on rearranging gives the value of spring constant k .

NB:

- After the spring is loaded, make sure that it does not detach from the clamp when oscillating.
- As it is oscillating, make sure that it describes a vertical straight path.

4.8. Rotation of Rigid bodies

A rigid body is an object that has a fixed shape and size. It can be **regular** or **irregular**. When a rigid object rotates, every part (particles) moves in a circle, covering the same angle within the same amount of time. Every particle has a different velocity vector. Since all the velocities differ, we cannot measure the speed of rotation of the top by giving a single velocity. We can, however, specify its speed of rotation consistently in terms of the angle per unit time. When a body is free to rotate on an axis, the torque must be applied to change its angular momentum. The amount of torque needed to cause any given angular acceleration (the rate of change in angular velocity) is proportional to the moment of inertia of the body. The moment of inertia

depends on how mass is distributed around the axis of rotation and variations depend on the chosen axis. Moment of inertia, by definition, refers to the product of mass of a section and the square of the distance between the reference axis and the centroid of the section. The Moment of inertia may be expressed in units of kilogramme metre squared ($\text{kg}\cdot\text{m}^2$) as SI units.

Specific objectives

The teacher/laboratory technician should prepare an experiment for candidates to:

- determine the moment of inertia of a rotating rigid body; and
- deduce the radius of gyration of a rotating rigid body.

Apparatuses/materials

Apart from the common fittings in the laboratory, teachers in charge/laboratory technicians ought to prepare apparatuses and materials based on the checklist provided. The experiments conducted under this topic should include the following apparatuses and materials:

Rigid rods (metal/wooden), discs, cylinders, spheres, lamina, stopwatches, metre rulers, optical pins, retort stands with their accessories, pendulum bobs, inextensible strings/cotton threads, cardboards each of diameter 30 cm with holes 5 cm apart, and standard masses.

Sample Question: Determination of the radius of gyration of circular sheet of cardboard.

Apparatuses and materials

Apart from the normal laboratory fittings, teachers in charge/laboratory technicians should prepare the following apparatuses and materials for each set of the experiment:

Retort stand with its accessories, circular sheet of cardboard of diameter of 30 cm with holes 5 cm apart, optical pin, and stopwatch.

Procedures

- (a) Suspend the cardboard from the hole nearest its centre of gravity, G and record the distance, l between the point of suspension and G as shown in Figure 22:

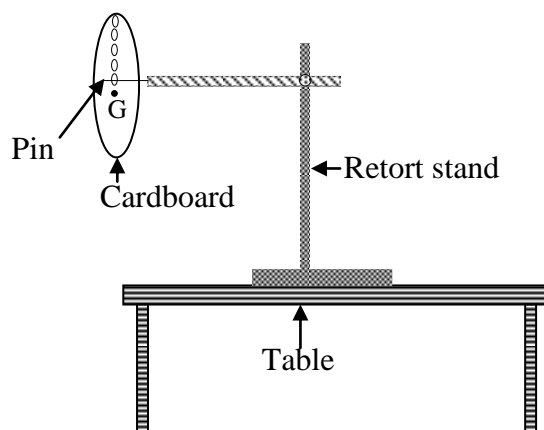

Figure 22

- (b) Displace the cardboard through a small angle so that it oscillates on a vertical plane.

- (c) Use the stopwatch to record the time, t for 10 complete oscillations and, hence, determine its periodic time, T .
- (d) Repeat the procedure in part (c) with four other values of l .
- (e) Tabulate the results including the column for l^2 , T and T^2 .
- (f) Plot a graph of l^2 against T^2l .
- (g) Use the graph and the equation, $T^2l = \frac{4\pi^2}{g}(\mathbf{K}^2 + l^2)$ to determine the radius of gyration, \mathbf{K} and acceleration due to gravity, \mathbf{g} .

4.9. Fluid Dynamics

Viscosity refers to the measure of the resistance of a fluid to gradual deformation by shear or tensile stress. In other words, viscosity describes a fluid's resistance to flow. Basically, honey is thicker than water; thus, honey is more viscous than water.

Coefficient of viscosity of the liquid is defined as the viscous force acting per unit area between two adjacent layers of a liquid per unit velocity gradient normal to the direction of the flow of

the liquid. Mathematically, coefficient of viscosity, η is given by $\eta = \frac{F}{A \frac{dv}{dx}}$ and its S.I unit is $\text{kg m}^{-1}\text{s}^{-1}$.

According to Stokes' Law the frictional (viscosity) force acting on a sphere of radius, r is $F = 6\pi\eta rv$.

Specific objective

- Determination of coefficient of viscosity of liquid by using Stokes' Law.

Apparatuses and materials

When a checklist is sent to schools/colleges, teachers in charge/laboratory technicians must make sure that all the apparatuses and materials listed are available. For this topic, the following list of apparatuses and materials should be prepared:

Viscous liquid, measuring cylinders, ball bearings of different sizes (ranging from 2 mm to 12 mm in diameter), rubber bands, forceps, metre rules, marker pens, bar magnets, small dishes, micrometre screw gauges, stopwatches, retort stands and their clamps.

Sample Question: In this experiment, you are required to determine the coefficient of viscosity of glycerine.

Apparatuses and materials

Apart from the normal laboratory fittings, teachers in charge/laboratory technicians should prepare the following apparatuses for each set of the experiment:

Glycerine, measuring cylinder of 250 ml or 500 ml, five steel ball bearings of different sizes (ranging from 2 mm to 12 mm in diameter), marker pen, a bar magnet, small dish, a metre rule, forceps, micrometer screw gauge, stopwatch, and thermometer.

Procedures

- (a) Measure and record the volume, V and mass, M of the given glycerine, hence determine its density, σ .
- (b) Arrange the apparatuses as shown in Figure 23 and then fill the measuring cylinder with glycerine.

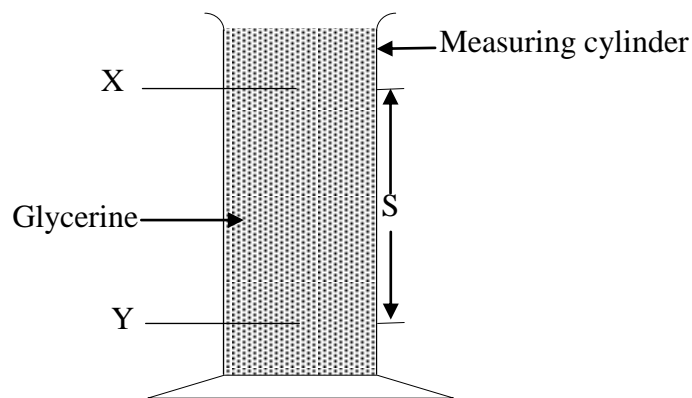

Figure 23

- (c) Determine and write down the diameters of all the steel ball bearings using the micrometer screw gauge provided. Then, wet all the ball bearings with glycerine by keeping them in a small dish containing the liquid.
- (d) Starting with the smallest ball bearing, use the forceps to release the ball at the meniscus of glycerine in the measuring cylinder and record the time the ball takes to fall over a distance S between X and Y as shown in Figure 23. Point X should be chosen so that the distance from the meniscus of glycerine to X is at least 4cm. Meanwhile, point Y should be at least 20 cm away from X . Measure and record the distance, S with a metre rule. You may use the bar magnet to pull the balls out of the glycerine in the measuring cylinder.
- (e) Repeat procedure (d) by releasing four other balls in the order of lengths of the diameter.
- (f) Tabulate your results including the average diameter and the square of the radius (r^2) of each ball in cm and cm^2 , respectively, and the average terminal velocity, v of each ball in cm/sec. Record the room temperature.
- (g) Plot a graph of r^2 against v and determine its slope.
- (h) Determine the coefficient of viscosity h of glycerine using the relation:

$$9hv - 2gr^2(r - s) = 0$$
 where the density, r of steel ball bearings is 7.5 gm/cm^3 .
- (i) State the law which governs this experiment.

4.10. Light

Light is electromagnetic radiation that can be detected by the human eye. Electromagnetic radiation occurs over an extremely wide range of wavelengths, from gamma rays with wavelengths of less than about 1×10^{-11} metres to radio waves measured in metres. It travels in a straight line and can be reflected, refracted, interfered, diffracted and polarized. When a ray of light falls on any object (polished, smooth or shiny) it can bounce back to our eyes. This phenomenon is known as *reflection of light*. Likewise, *refraction of light* can also be observed in a glass prism. A prism is a solid piece of glass that has at least two planes inclined towards each other, through which light is refracted. Prisms are divided into two types: **Rectangular** and **triangular** prisms. When a beam of light strikes the surface of a transparent material (glass,

water, quartz crystal, and others.), a portion of the light is transmitted and another portion is reflected. The transmitted light ray has a small deviation of the path from the incident angle. This phenomenon is called refraction. Refraction is due to the change in the speed of light while passing through a medium. It is given by Snell's Law: $\frac{\sin i}{\sin r} = \frac{n_2}{n_1}$, where i is the angle of incident, r is the angle of refraction, n_1 is the refractive index of the first medium, and n_2 is the refractive index of the second medium.

Specific objectives

- Verification of laws of reflection of light.
- Determination of refractive index of glass using a rectangular glass prism or a triangular glass prism.
- Determination of refractive index of a liquid.

Apparatuses and materials

When a checklist is sent to schools/colleges, teachers in charge/laboratory technicians ought to make sure that all the apparatuses and materials listed are available. For this topic, the following list of apparatuses and materials should be organised:

Soft boards/drawing boards, plane mirrors, rectangular glass prisms, triangular glass prisms, optical pins, thumb pins/office pins, a ruler, a sheet of white plain paper (A4), protractor, a pencil, measuring cylinders or jar, metre rule, clear liquid e.g. water, and retort stands with its clamps.

Sample Question 1: Verification of laws of reflection of light by a plane mirror.

Apparatuses and materials

Apart from the normal laboratory fittings, teachers in charge/laboratory technicians should prepare the following apparatuses for each set of the experiment:

Soft board/drawing board, plane mirror, four optical pins, thumb pins/office pins, a ruler, five sheets of white plain paper (A4), protractor, pencil, and pencil sharpener.

Procedures

- (a) Place a plain paper on the soft board and pin it using thumb pins.
- (b) Draw a line L_1L_2 across the paper and align the plane mirror on it.
- (c) Locate a point O in the middle of the mirror and then draw a line ON normal to the mirror from point O .
- (d) Draw a line OA to make an angle of 20° from the normal and call it angle of incidence i .
- (e) Fix two Optical pins P and Q on the straight-line AO at least 8cm apart.
- (f) Observe if the images of the pins P and Q and fix two pins S and T such that S , T and images of P and Q are all in the same straight line from O to C making angle, r from the normal.

- (g) Remove the pins and draw small circles around the pin pricks. Remove the mirror as well.
- (h) Join S and T and produce a straight line to meet at O. Measure $\angle AON = i$ and $\angle CON = r$.
- (i) Repeat procedures (d) to (h) for angle of incidence $i=30,40,50$ and 60 . Tabulate your results.
- (j) Draw a graph of angle of incidence i against angle of reflection r .
- (k) Determine the slope of your graph.
- (l) State the law governing this experiment.
- (m) What is the relation of angle i and angle r ?

Discussion

It will be found that $i = r$. This proves that the angle of incidence is equal to the angle of reflection. As the incident ray, the reflected ray and the normal lie in the plane of the paper, therefore, they lie in the same plane.

Sample Question 2: Determination of minimum angle of deviation and refractive index of glass by using triangular glass prism.

Apparatuses and materials

Apart from the normal laboratory fittings, a teacher in charge/laboratory technician should prepare the following apparatuses in each set of the experiment:

Soft board/drawing board, four optical pins, thumb pins/office pins, a ruler, five sheets of white plain paper (A4), protractor, pencil, triangular glass prism, and pencil sharpener.

Procedures

- (a) Place the prism on a white plain paper fixed on a drawn board and trace its edges using a sharp pencil.
- (b) Remove the prism and draw a line XY and mark its midpoint Q and draw normal NQM at the right angles to XY by a dotted line.
- (c) Draw a line PQ whose angle of incidence, i ($\angle PQN$) is 30° is as shown in Figure 24.
- (d) Place the triangular prism vertically with the triangular base down on the paper so that the midpoint of the edge AB of the prism coincides with the midpoint Q of the line XY as shown in the Figure 24. Draw the outline ABC of the prism.

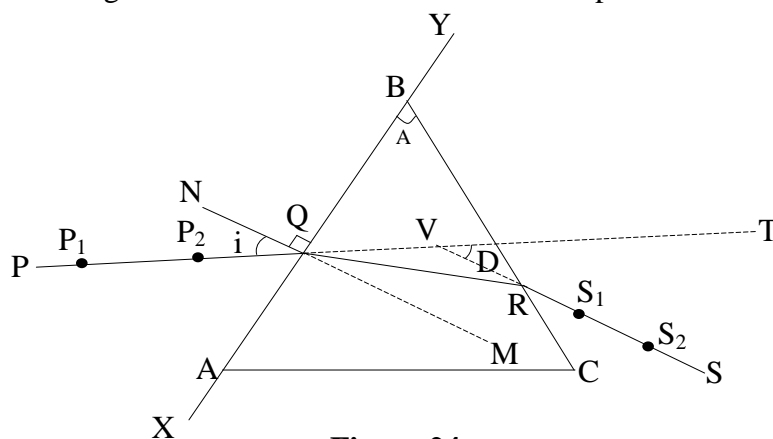

Figure 24

- (e) Fix two pins, P1 and P2, on the line PQ vertically into the soft board about 5 cm apart. View from the side BC of the prism and look for the images of the pins P1 and P2. Keeping the eye along the plane of the paper, fix search pins S1 and S2 one after the other between the eye and the prism so that S1 and S2 are images of P1 and P2 seen through the prism appear one is behind the other in a straight line. Mark the positions of the four pins and remove the pins, prism, and the paper.
- (f) Draw the emergent ray RS and the reflected ray QR inside the prism. Produce the incident ray PQ to T by a dotted line. Produce SR backward to meet the line PT at V by a dotted line, measure the angle D, called the angle of deviation $\angle TVS$ produced by the prism for the incident ray PQ. Also measure angle A, the angle of prism $\angle ABC$.
- (g) Repeat the procedures for the values of, $i = 35^\circ, 40^\circ, 45^\circ$ and 50° .
- (h) Tabulate the results as shown in the following table:

i°	30°	35°	40°	45°	50°
D°					

- (i) Plot the graph of angle, D° against angle, i° .
- (j) From the graph determine the angle of minimum deviation, D_m .

- (k) The refractive index of the material used in the prism can be shown as $n = \frac{\sin \frac{A + D_m}{2}}{\sin \frac{A}{2}}$,

where D_m is the angle of minimum deviation and A is the angle of the prism. Determine the refractive index of the materials of the prism.

Sample Question 3: Determination of refractive index of a liquid by real and apparent depth method.

Apparatuses and materials

Apart from the normal laboratory fittings, teachers in charge/laboratory technicians should prepare the following apparatuses for each set of the experiment:

Tall jar or measuring cylinder of 300 ml, retort stand, two optical pins, a pin fixed on a cork, a metre rule, and clear liquid e.g. water.

Procedures

- (a) Set up the apparatus as shown in Figure 25:

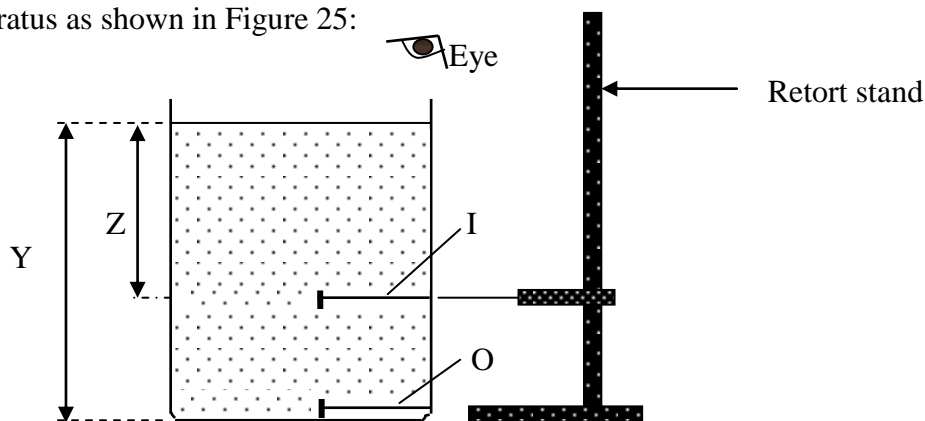

Figure 25

- (b) Place one pin (object pin) at the bottom of the measuring cylinder so that it rests touching the wall of the cylinder and then fill the measuring cylinder with water of about 150cm³ whose refractive index is to be determined.
- (c) Clamp the pin fixed onto the cork (search pin) as shown in Figure 25. Move the search pin up and down along the edge of the measuring cylinder until there is no parallax between the search pin and the image of the pin at the bottom of the cylinder. Locate the image position and measure its depth Z from the surface of the liquid. Also, measure the depth Y of the liquid from its free surface to the object pin.
- (d) Repeat the experiment with 175cm³, 200cm³, 225cm³, and 250cm³ of water in the measuring cylinder. Tabulate your results for the volume of liquid V in the measuring cylinder Z and Y.
- (e) Plot the graph of Y versus Z.
- (f) Determine the slope of the graph.
- (g) What is the physical meaning of the slope?
- (h) State two sources of errors and precautions taken in this experiment.

4.11. Heat/Measurement of Thermal Energy

Thermal energy (heat) is transferable from one point to another due to temperature difference. Thermal energy is, sometimes, called **internal energy in transit**. The heat content of a substance is determined by its mass, temperature change and specific heat capacity. However, temperature is a direct measurement of thermal energy, meaning that the hotter the substance, the more thermal energy it contains. During practical sessions, teachers in charge/laboratory technicians should prepare experiments for students to determine the specific heat capacity and the melting points of substances.

Specific objectives

- Determination of the specific heat capacity of a substance.
- Determination of the melting point of a substance from its cooling curve.
- Determination of the latent heat of fusion and vaporisation.
- Determination of the rate of heat flow.
- Investigation of factors that affect the rate of cooling.

Apparatuses and materials

Apart from the common fittings found in the laboratory, teachers in charge/laboratory technicians should prepare apparatuses and materials based on the checklist provided. The experiments conducted under this topic should include the following apparatuses and materials:

Blocks of metal (e.g. aluminium, brass, zinc, or iron of about 200 g, beakers (200 cm³, 250 cm³ and 500 cm³), copper calorimeters with insulating jacket and stirrers, tripod stands with wire gauze, bunsen burners, beam balance (to be shared), cotton thread (about 35cm long), thermometers (0 °C to 100 °C), alcohol, boiling test tubes, stopwatches, retort stands with their clamps, water, naphthalene/wax, lagged metal rod, ice, vernier callipers, and cotton wool.

Sample Question 1: Determination of specific heat capacity of a brass by the method of mixtures.

Apparatuses and materials

Apart from the common fittings found in laboratory, teachers in charge/laboratory technicians ought to prepare apparatuses and materials based on the checklist provided. The experiments conducted under this topic should include the following apparatuses and materials:

Metal block of brass of mass 200 g, beaker (200 cm³ or 250 cm³), copper calorimeter insulating jacket and stirrer, tripod stand with gauze, bunsen burner (source of heat), beam balance (to be shared), cotton thread (about 35 cm long), and thermometer (0 °C to 100 °C)

Procedures

- (a) Measure and record the mass of metal brass as M_m .
- (b) Tie the metal brass with the given thread; immerse it into the beaker filled with water and heat the content.
- (c) While heating, measure the mass of an empty calorimeter with a stirrer and record it as M_c .
- (d) Half-fill the calorimeter with cold water so that the metal brass is immersed completely and measure the mass of cold water and calorimeter and record it as M .
- (e) Find the mass of cold water and record it as M_w .
- (f) When water in the beaker boils, record its temperature as θ_h . Also measure the temperature of the cold water in the calorimeter and record its value as θ_0 .
- (g) Quickly transfer the metal brass from hot water to the calorimeter with cold water and start the stopwatch.
- (h) Keep stirring until the mixture attains a steady temperature. Record this constant temperature as θ_f .
- (i) Assuming no heat is lost because of the surroundings, develop an equation which shows the heat exchange.
- (j) Using the equation developed in part (i), calculate the specific heat capacity, C_b of brass.

Sample Question 2: Determination of melting point of Naphthalene.

Apparatuses and materials

Apart from the common fittings in the laboratory, teachers in charge/laboratory technicians should prepare apparatuses and materials based on the checklist provided. The experiments conducted under this topic should include the following apparatuses and materials:

Test tube (Pyrex), stopwatch, thermometer (0 °C to 100 °C), retort stand with its clamps, beaker of 500 cm³ (pyrex), water, tripod stand, and 20 g of naphthalene.

Procedures

- (a) Put 20 g of Naphthalene in a test-tube.
- (b) Hang the test-tube vertically using a retort stand.

- (c) Put some water of volume 250 cm^3 in a 500mls beaker provided. Lower the test-tube in the beaker as shown in Figure 26:

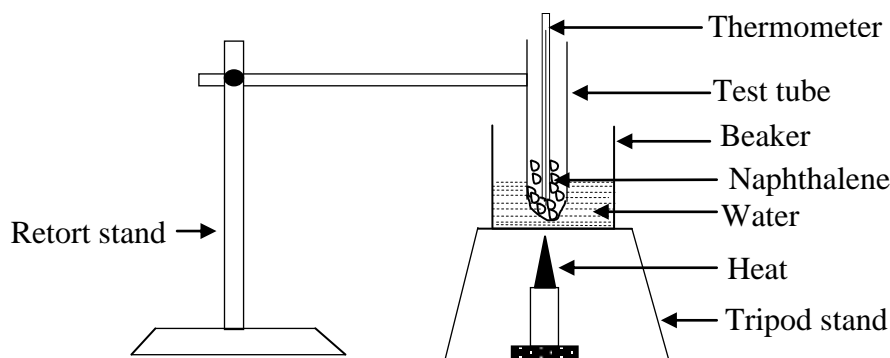

Figure 26

- (d) Heat the water to warm the test-tube until the Naphthalene melts. Record its temperature as θ_n .
- (e) Insert the thermometer into the melted Naphthalene and continue heating up to about 89°C .
- (f) Turn off the heat simultaneously, start the stopwatch and record the temperature falls, θ at an interval of 30 seconds for 16 minutes.
- (g) Tabulate your results.
- (h) Plot a graph of temperature, θ against time, t .
- (i) Use your graph to determine the melting point.
- (j) Compare the temperature of the melting point of Naphthalene which was obtained from the graph with that obtained in part (d).

Sample question 3: Verification of Newton's Law of Cooling.

Apparatuses and materials

When a checklist is sent to schools/colleges, teachers in charge/laboratory technicians must make sure that all the apparatuses and materials listed are available. For this topic, the following apparatuses and materials should be prepared:

Copper calorimeter with its accessories, a thermometer, a stopwatch, a heater/ burner, liquid (water), a retort stands with its clamp, a Beaker of 250 ml, and wooden block of $20\text{ cm} \times 10\text{ cm} \times 7\text{ cm}$.

Procedures

- (a) Fill the beaker provided with some cold water.
- (b) Heat the beaker and its content on a Bunsen burner (or any other heating source) until the water reaches a temperature of about 90°C .
- (c) Then, pour the hot water into the calorimeter until it is about three quarters full before setting the calorimeter up as shown in Figure 27:

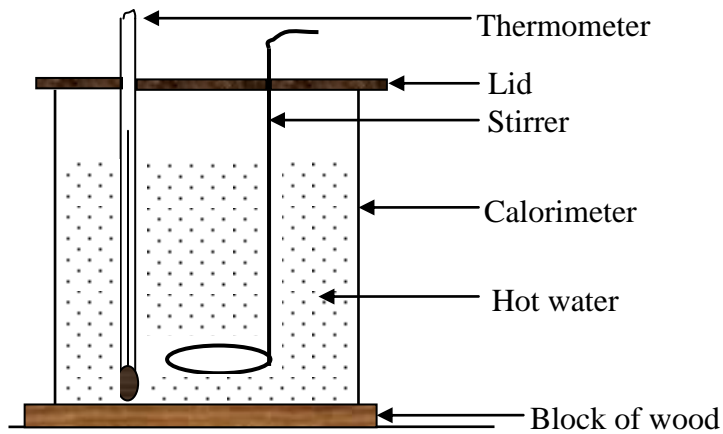

Figure 27

- (d) Carefully observe and record the temperature, θ of the water inside the calorimeter after every two minutes.
- (e) Continue with the process while stirring the water in the calorimeter until the temperature of the water drops to about 50°C .
- (f) Tabulate the values of temperature, θ and the corresponding values of time, t (in minutes) starting at $t = 0$). Also measure and record the room temperature, θ_r .
- (g) Plot a cooling curve for the calorimeter and its content using the table in part (f).
- (h) Choose six points (t, θ) along the curve in part (g) and at each point draw the tangent to the curve and then determine the gradient, S to the curve at that point. Calculate and record the excess temperature $(\theta - \theta_r)$ corresponding to each of the six points chosen. Hence, prepare a table that consists of values of S and values of $(\theta - \theta_r)$.
- (i) Using the results in part (h) draw a graph of the rate of cooling, S against “excess temperature” $(\theta - \theta_r)$.
- (j) State Newton’s Law of Cooling. Compare the results in (i) with Newton’s Law of Cooling and comment on the outcome.

Discussion

The rate at which a hot body loses heat is directly proportional to the difference between the temperature of the hot body and that of its surroundings. Also, the nature of material and the surface area of the body affect the rate of loss of heat. This is Newton’s Law of Cooling. For a body of mass m and specific heat capacity c at its initial temperature θ higher than its surrounding’s temperature θ_r , the rate of loss of heat is $\frac{dQ}{dt}$. Following Newton’s Law of

Cooling we have rate of loss of heat, $\frac{dQ}{dt} = -k(\theta - \theta_r)$ and $\frac{dQ}{dt} = mc \frac{d\theta}{dt}$. By equating these two

equations gives $\frac{d\theta}{dt} = -\frac{k}{mc}(\theta - \theta_r)$, where k is the constant of proportionality depending on the

nature and surface area of the cooling content. A negative sign appears in the equations because

loss of heat signals a drop in temperature. This can be written as $\frac{d\theta}{dt} = -k'(\theta - \theta_r)$ where $k' = \frac{k}{mc}$

(depending on the nature, surface area and heat capacity). Integrating, we get $\ln(\theta - \theta_r) = \log_e(\theta - \theta_r) = -k't + z$ where z is the constant. The nature of the graph of $\log_e(\theta - \theta_r)$ against t will be a straight line with negative slope.

Conclusion

If the graph drawn emerges as a straight line, it implies that the liquid under investigation obeys Newton's Law of Cooling and, hence, the law is verified.

Sample Question 5: Determination of the factors affecting the rate of cooling.

Apparatuses and materials

Apart from the normal laboratory fittings, teachers in charge/laboratory technicians should prepare the following apparatus in each set of the experiment:

Calorimeters with its accessories, kerosene burner, metal foil (aluminium), hot water labelled H, thermometer, measuring cylinder of 250 ml, stopwatch, wooden slab (20 cm × 10 cm × 7 cm), and two rubber bands.

In this experiment, you are required to compare the time taken by a substance to cool based on a fixed temperature range for a blackened calorimeter and the same calorimeter covered with metal foil.

Procedures

- (a) You are provided with a container labelled H and a blackened calorimeter. Nearly fill the blackened calorimeter with hot water whose initial temperature should be about 80 °C and place this calorimeter on a wooden slab placed on a bench.
- (b) Stir the hot water in the blackened calorimeter constantly and record the temperature fall θ of the water at one-minute interval. Continue recording the temperature θ until it has fallen to about 60 °C.
- (c) Pour the water from the calorimeter into the measuring cylinder and record its volume as V_0 .
- (d) Cover the outer surface of the same calorimeter (after washing) with the metal foil provided by using rubber bands. Use the same volume V_0 of hot water at about 80 °C as in part (c) to fill the calorimeter covered with foil. Then, repeat the procedures outlined in part (b). Note that the initial temperatures should be the same for both cases.
- (e) Using the same axes, draw the cooling curves for the blackened calorimeter with its content and calorimeter with a metal foil together with its content.
- (f) From each curve, estimate the time taken to cool from 80 °C to 60 °C. With reasons, comment on your results.

Discussion

Regardless of the excess temperature, the rate of heat loss depends on the exposed area of the calorimeter, and on the nature of its surface: A dull surface (blackened in a candle flame) loses heat a little faster than a shiny (covered with metal foil) one because it is a better radiator. In general, for any body with a uniform surface at a uniform temperature, we may write, if Newton's law is true, then $\frac{\text{Heat lost}}{\text{Time}} = \frac{dQ}{dt} = k(\theta - \theta_r)$, where k depending on both the nature and the surface area, θ_r is the temperature of the surroundings, and dQ denotes the heat lost from the body.

4.12. Vibrations and Waves

Waves refer to vibrational movements (to and from movement) that transfer energy from one point to another. There are essentially two types of waves: **Mechanical** and **electromagnetic**. Under mechanical waves, we also study other concepts pertaining to the propagation of sound waves in pipes. During practical sessions, therefore, teachers in charge/laboratory technicians should prepare experiments for students to determine the velocity of sound in air and the end correction by using resonance tubes.

Specific objective

- Determination of the velocity of sound waves in air and the end correction of the resonance tube.

Apparatuses and materials

Apart from the common fittings in the laboratory, teachers in charge/laboratory technicians ought to prepare apparatuses and materials based on the checklist provided. The experiments conducted under this topic should include the following apparatuses and materials:

Resonance tubes/burette with a tap, turning forks of different frequencies, metre rules, water, rubber hummer, and retort stands with their clamps.

Sample Question: Determination of velocity of sound, v and the end correction, e .

Apparatuses and materials

Resonance tubes/burette with a tap, turning forks of different frequencies (341 Hz, 384 Hz, 426 Hz, 480 Hz and 512 Hz), a metre ruler, water, rubber hummer, retort stand with its clamp, and 250 ml beaker.

Procedures

- (a) Set up the apparatus as shown in Figure 28:

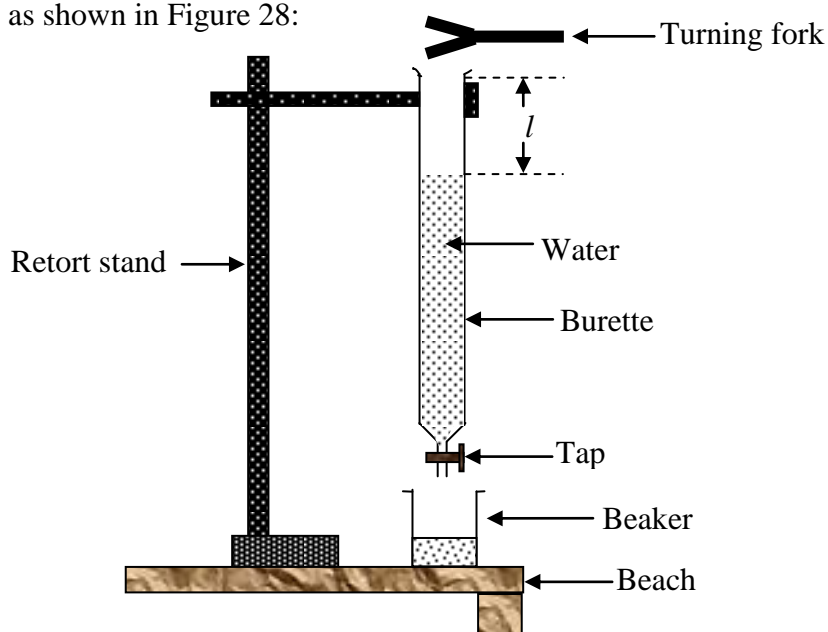

Figure 28

- (b) Fill the burette with water to its brim.
- (c) Hold a tuning fork of a frequency, $f=314$ Hz horizontally near the burette at its upper end. Strike it with a rubber hammer.
- (d) Open the tap to allow water to flow. Close the tap just when you hear the loudest sound (resonance at its fundamental mode) and record the length l (cm).
- (e) Repeat procedures (b) and (c) for $f=384$ Hz, 426 Hz, 480 Hz and 512 Hz tabulate your results including the column for f , $\frac{1}{f}$ and l .
- (f) Plot a graph of $\frac{1}{f}$ against l .
- (g) From the graph determine (i) the slope and (ii) $\frac{1}{f}$ - intercept.
- (h) Use the values calculated in (g) and the equation $f = \frac{v}{4(l+e)}$ to determine the velocity, v of sound in air and the end correction, e .
- (i) Mention two sources of errors and precautions taken in this experiment.

4.13. Current Electricity

Current electricity is a study which deals with electric charges in motion; it is sometimes called **electrodynamics**. Materials that allow the flow of electric charges are called conductors. Thus, electric current is the flow of electric charges through a conductor per unit time measured in amperes (A). An electric circuit may comprise the following: devices that generate electric current (such as a battery or a generator), devices that use electric current (radio, computer, phones and many others), switches, resistors, ammeters, voltmeters, and the connecting wires or transmission lines. In conductors, electric current is constituted by electrons as charge carriers.

Ohm's Law states the relationship among the three quantities: **Voltage**, **current**, and **resistance**, thus $V = IR$ where I is the electric current measured in units of amperes, (A), V is the potential difference in units of volts, (V) and R is the resistance in units of Ohms, (Ω). The law states: "At a constant temperature and other physical factors, the electric current ' I ' through a conductor is directly proportional to the potential difference ' V ', across the conductor".

A meter bridge is used to determine an unknown resistance using some known resistances. It has two gaps formed using thick metal strips. Its working principle is like that of a Wheatstone's bridge. Notably, when the galvanometer reads zero, then the meter bridge (Wheatstone's bridge) is balanced. When the circuit is balanced, the value of unknown resistance can be calculated.

Specific objectives

- Measurement of electric current and voltage.
- Verification of Ohm's Law.
- Measurement of the electromotive force and potential difference across a conductor.
- Determination of the electromotive force and internal resistance of the cell.
- Investigation of the factors affecting the resistance in the conducting wire.

- Determination of the unknown resistance using the meter bridge circuit.

Apparatuses and materials

When a checklist is sent to schools/colleges, teachers in charge/laboratory technicians should make sure that all the listed apparatuses and materials are available. For this topic, the following list of apparatuses and materials should be prepared:

Dry cells (Batteries), standard resistors of different resistances, ammeters, voltmeters, rheostats, metre bridges, plug keys/switches, coil of unknown resistance (resistance wires), connecting wires, potentiometers, resistance boxes, wheatstone bridges, galvanometers, battery holders, wire clips, soldering wires, solder gun, cello tape, masking tape, constantan wires of different values (SWG 26, SWG 28, SWG 30, SWG 32), crocodile clips/jockeys, nichrome wires of different values (SWG 26, SWG 28, SWG 30, SWG 32), manganin wires of different values (SWG 26, SWG 28, SWG 30, SWG 32), and electric bulbs of different ratings.

Sample Question 1: Verification of Ohm’s Law.

Apparatuses and Materials

Apart from the normal laboratory fittings, teachers in charge/laboratory technicians should prepare the following apparatuses in each set of the experiment:

Battery (two size “D” dry cells connected in series), an ammeter (0 A to 3 A), Voltmeter (0 V to 3 V), rheostat (0 Ω to 50 Ω), plug key, coil of unknown resistance labelled R, and eight (8) connecting wires.

Procedures

- (a) Set up the apparatus as shown in Figure 29.

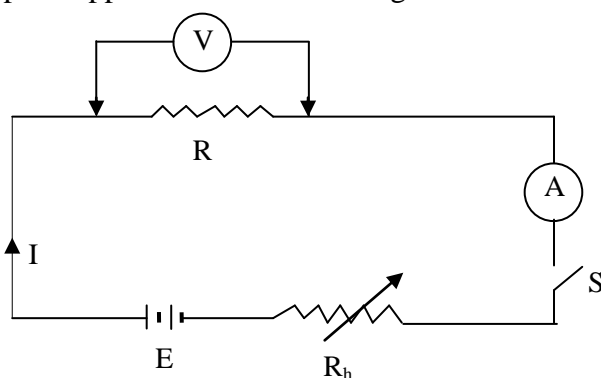

Figure 29

- (b) Close the switch S.
 (c) Adjust the rheostat, Rh by sliding slowly from one end.
 (d) Read and record the value of potential difference V across the conductor and current, I from the voltmeter and ammeter readings, respectively.
 (e) Repeat the experiment by changing the position of the slider of a rheostat for four other readings.
 (f) Always adjust the rheostat until the ammeter pointer is exactly on the division of the meter scale before taking the reading.

- (g) Prepare the results as shown in the following table:

Potential difference V (volts)					
Current I (amperes)					

- (h) Plot a graph of V against I.
 (i) Find the slope of the graph.
 (j) What is the physical meaning of the slope?
 (k) State the possible sources of errors in this experiment.
 (l) What are the precautions to be taken in performing this experiment?

Discussion

A resistor (conductor) obeys the Ohm's Law. However, not all the conducting devices obey Ohm's Law e.g. diode, thyristor and others. These are called **non-ohmic conductors**. In preparing the apparatuses and materials in the laboratory, the teacher or laboratory technician should not attempt to use a material which does not obey Ohm's law (e.g. diode) in place of a resistor which electrically gives linear relationship between current and voltage.

Sample Question 2: Determination of electromotive force (e.m.f.) and internal resistance of a cell.

Apparatuses and Materials

Apart from the common fittings in the laboratory, teachers in charge/laboratory technician is recommended to have the following:

Resistance box labelled R (0Ω to 100Ω), One size "D" dry cell labelled "E", Tapping key (Switch) labelled K, Ammeter labelled A (0 A to 2 A), and Five (5) connecting wires.

Procedures

- (a) The arrangement of the equipment should be as shown in Figure 30:

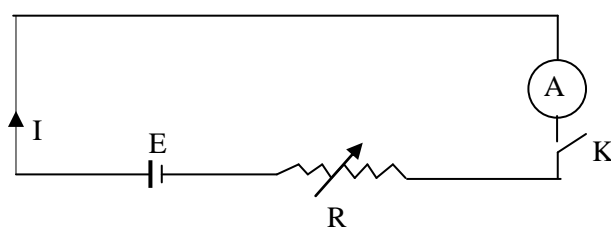

Figure 30

- (b) With the tapping key closed, note and record the current reading I of the ammeter when $R = 4 \Omega$.
 (c) Repeat the procedure in part (b) for values of R equal to 6Ω , 8Ω , 10Ω , 12Ω , 15Ω , 20Ω , and 25Ω . Tabulate your results in a table as shown below:

R (Ω)	4	6	8	12	15	20	25
I (A)							
1/A (A^{-1})							

- (d) Plot a graph of R against $\frac{1}{I}$ and determine its gradient.
- (e) From your graph determine the e.m.f. of a cell.
- (f) Determine the value of R for which $\frac{1}{I} = 0$.
- (g) State the physical significance of the value of R obtained in part (f).

Sample question 3: Determination of unknown resistance using the meter bridge circuit.

Apparatuses and Materials

Apart from the common fittings in the laboratory, each teacher in charge/laboratory technician is recommended to have the following:

A resistance box R capable of providing resistances of magnitude 5 Ω, 10 Ω, 15 Ω, 20 Ω, 25 Ω and 30 Ω, one size D dry cell labelled E, switch labelled K, a metre bridge, a standard resistor S of unknown resistance, a Galvanometer G, a jockey J and some connecting wires.

Procedures

- (a) The arrangement of the equipment should be as shown in Figure 31.

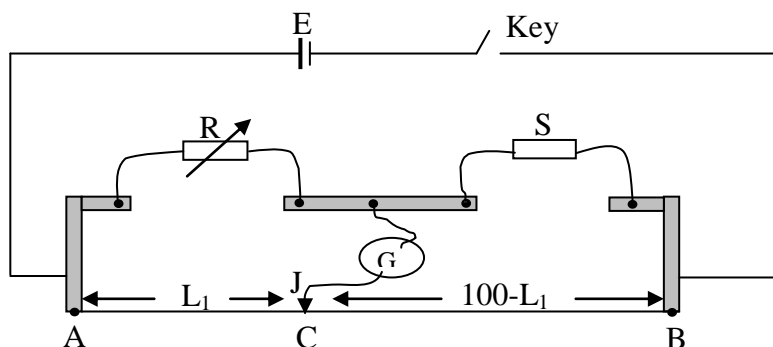

Figure 31

- (b) Starting with R = 30 Ω, find the balance length AC= L_1 along the metre bridge wire AB to the nearest centimetre.
- (c) Repeat the procedure in part (b) for other values of R obtained by decreasing in steps of 5 Ω up to R = 5 Ω.
- (d) Tabulate the values of R against L_1 and include in your table the values of $P = \frac{L_1}{100-L_1}$.
- (e) Plot a graph of P against R.
- (f) Evaluate (i) the slope M of the best line (ii) the reciprocal N of M where $N = \frac{1}{M}$.
- (g) Write the formula of the balanced bridge, hence discuss the physical meaning of N.
- (h) Identify any two sources of errors in this experiment.
- (i) Give two precautions that must be taken in performing this experiment?

Sample question 4: Determination of unknown resistance, R and resistivity ρ using the meter bridge circuit.

Apparatuses and Materials

Apart from the common fittings in the laboratory, teachers in charge/laboratory technicians need to have the following:

One size D dry cell labelled E, switch labelled K, a metre bridge, a standard resistor R of unknown resistance ($R = 1 \Omega$, to be covered), a galvanometer G, a jockey J, crocodile clip, constantine wire (SWG 28) labelled W of length 150 cm, and some connecting wires.

Procedures

- (a) Connect the resistor R and the wire W in series. Connect the free end of R to the left terminal of the right-hand gap of the metre bridge. Next, connect the wire W with the crocodile clip C to the other terminal of the right-hand gap.
- (b) Connect 5Ω resistor in the left-hand gap and hence complete the Wheatstone bridge circuit in the usual manner.
- (c) Draw a circuit diagram of the set up outlined in (a) and (b).
- (d) Measure the length X of the wire W equal to 20 cm and clip the crocodile clip C at the end of this length. Find the balance length l as measured from the end with 5Ω resistor. Calculate the equivalent resistance R_e in the right-hand gap. Increase X by 20cm each time and obtain corresponding values of X and R_e . Tabulate your readings (a total of 6 readings are required).
- (e) Measure the diameter of the wire W.
- (f) Plot a graph of R_e against X.
- (g) Using your graph, deduce (i) the value of unknown resistance R (ii) the resistance per unit length of the wire W.
- (h) Find the resistivity of the material of the wire W.
- (i) State any two sources of error and precautions taken in this experiment.

5.0 CONCLUSION

This guidebook has been designed to equip teachers in charge/laboratory technicians with relevant skills and expose them to appropriate procedures of handling the laboratory for conducting smoothly Physics practical examinations. It offers guidance on how to organise and manage the laboratory and how to effectively prepare apparatuses, equipment and materials based on the checklists provided.

In this guidebook, the credibility of the content is to identify effective strategies for dealing with correct experimental procedures in different areas of assessment. The guidebook is also meant to facilitate the teachers'/laboratory technicians' acquisition of techniques for executing the instructional procedures in order to for attain the same practical conclusions during the teaching and learning process.

Therefore, the guidelines will be useful to teachers, laboratory technicians and students as they provide a complete understanding of the experimental attempts, preparation and calibration of the measuring instruments in addition to their associated troubleshoots. In short, this guidebook will help good preparation for Physics practical examinations within time as prescribed in the three (3) hours advance instructions.

